

inventronics

# Technical application guide

PrevaLED® Linear G5/G6



---

**Contents**

<b>1 Introduction</b>	<b>03</b>	<b>5 Thermal considerations</b>	<b>43</b>
1.1 PrevaLED® Linear G5/G6	03	5.1 Introduction and definitions	43
1.2 System solution	03	5.2 $t_c$ location and measurement	43
1.3 Features and benefits	03	5.3 Forward voltage as a function of $t_c$ point temperature	44
1.4 LED module portfolio and nomenclature	04		
1.5 Electrical and optical data at typical conditions	05	<b>6 Lifetime and lumen maintenance</b>	<b>45</b>
1.6 Luminous flux as a function of forward current	10		
1.7 Luminous flux and efficacy as a function of $t_c$ point temperature	14	<b>7 Mechanical considerations</b>	<b>47</b>
		7.1 LED module dimensions	47
<b>2 Optical considerations</b>	<b>15</b>	7.2 Number of LEDs, LED pitch	52
2.1 Light distribution	15	7.3 Mechanical protection	52
2.2 Color temperature and coordinates	15	7.4 Mounting instructions	52
2.3 Spectral distribution	17		
2.4 Color rendering	18	<b>8 Safety information</b>	<b>54</b>
<b>3 Electrical considerations</b>	<b>19</b>		
3.1 Wiring information	19		
3.2 Disconnecting the wire from the connector	19		
3.3 Electrostatic discharge (ESD)	19		
3.4 Forward voltage as a function of forward current	20		
<b>4 LED systems: PrevaLED® Linear G5/G6 and OPTOTRONIC® LED drivers</b>	<b>29</b>		
4.1 LED module/driver combinations	29		
4.2 Installation examples	31		
4.3 System combination tables	34		

**Please note:**

All information in this guide has been prepared with great care. Inventronics, however, does not accept liability for possible errors, changes and/or omissions. Please check [www.inventronicsglobal.com](http://www.inventronicsglobal.com) or contact your sales partner for an updated copy of this guide. This technical application guide is for information purposes only and aims to support you in tackling the challenges and taking full advantage of all opportunities the technology has to offer. Please note that this guide is based on own measurements, tests, specific parameters and assumptions. Individual applications may not be covered and need different handling. Responsibility and testing obligations remain with the luminaire manufacturer/OEM/application planner.

# 1 Introduction

## 1.1 PrevaLED® Linear G5/G6

### Highly efficient, powerful, versatile

The PrevaLED® Linear G5/G6 LED module is characterized by its very high efficacy of up to 206 lm/W. This high-end lighting solution offers a wide range of light colors and lengths within the Zhaga LED module portfolio.

### Many luminaires, one answer

PrevaLED® Linear G5/G6 is mainly used in solutions for industrial and office lighting. Thanks to its high luminous flux, it can, for example, provide the powerful light needed for highbay luminaires. With a length of 1120 mm or 1400 mm, it can be easily integrated into trunking systems and provide reliable lighting for production sites. For office lighting projects, such as pendant or louver luminaires, surface-mounted or floor-standing luminaires, PrevaLED® Linear G5/G6 also offers unlimited possibilities.

The product portfolio offers the widest range of light colors, including 2700 K, 3000 K, 4000 K, 5000 K and 6500 K. Moreover, the product portfolio not only features a color rendering index of CRI > 80 but also an excellent color rendering index of CRI > 90 and thus offers the highest levels of light quality.

PrevaLED® Linear G5/G6 is matched to a broad range of OPTOTRONIC® Linear LED drivers – LV LED modules for SELV (parallel connection) as well as HV LED modules for non-isolated (serial connection), DALI or on/off, programmable or non-programmable. It is therefore ready for universal use.

## 1.2 System solution

We offer you the optimal combination of LED module and LED driver. By combining OPTOTRONIC® Linear LED drivers with PrevaLED® Linear G5/G6 LED modules, you always get the best possible system solution, which is perfectly complemented by useful accessories and modern LMS components for efficient and multifunctional light management.

## 1.3 Features and benefits

- Efficacy: Up to 206 lm/W
- Initial color consistency  $\leq 3$  SDCM
- CCT: 2700 K, 3000 K, 4000 K, 5000 K, 6500 K
- CRI: > 80, > 90
- Insulated connector with release function
- HV LED modules for serial connection
- LV LED modules for parallel connection
- Average lifetime (L80B50): 70000 h at  $t_c = 50^\circ\text{C}$
- Geometry according to Zhaga book 7 L28W2, L56W2
- CE, ENEC conformity and VDE certification



### 1.4 LED module portfolio and nomenclature

The PrevaLED® Linear G5/G6 portfolio is available in different lengths from 62 mm to 1400 mm as well as a wide range of different lumen packages from 245 lm to 5500 lm, provided by a single module. Almost every light application can be served by different color temperatures, including 2700K, 3000K, 4000K, 5000K and 6500K. The color rendering index of all PrevaLED® Linear G5/G6 LED module types is >80. Additionally, a high light quality with a CRI of >90 is achieved by PrevaLED® Linear G6 LED modules with a luminous flux of 1100lm, 2000lm, 2200lm or 4000lm.

The LED module nomenclature is explained below for the example of an LED module with the following characteristics: CCT = 4000K, CRI >80, nominal luminous flux = 1100lm, length = 560mm, width = 20mm, LV = optimized for parallel connection.

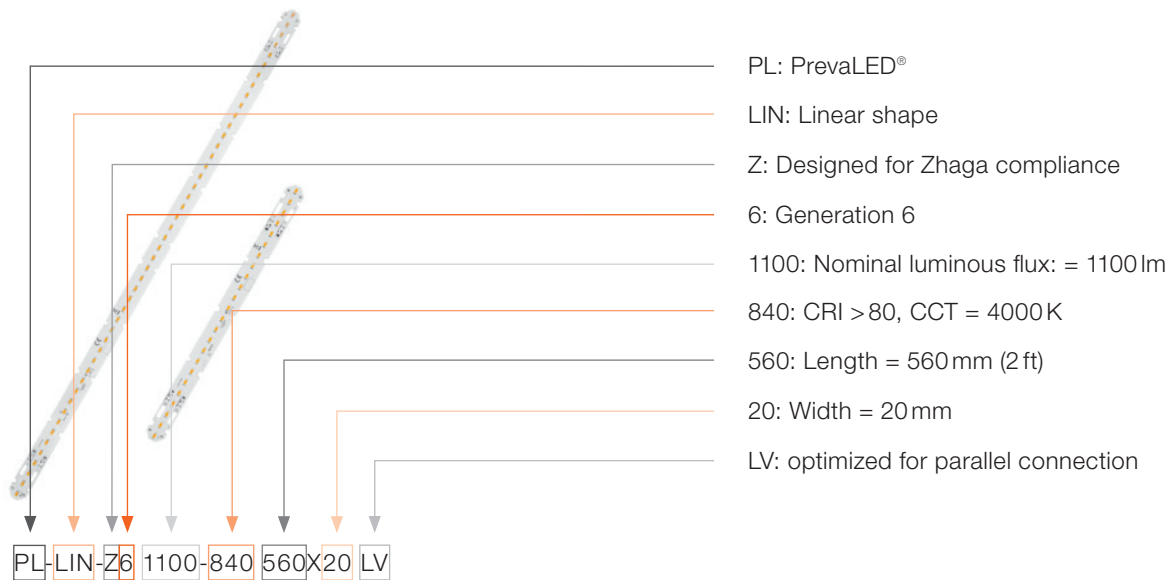

### 1.5 Electrical and optical data at typical conditions (for a $t_p$ temperature of 50 °C)

#### Nominal current Linear G5

Product name 20-mm module – CRI > 80	Flux [lm]*	CCT [K]	CRI	SDCM	Voltage [V]	Current [mA]	Power [W]*	Efficacy [lm/W]*
PL-LIN-Z5 1100-830 280X20-LV/HV	1027	3000	>80	3	23.5	250	5.9	174
PL-LIN-Z5 1100-840 280X20-LV/HV	1084	4000	>80	3	23.5	250	5.9	184
PL-LIN-Z5 1100-865 280X20-LV/HV	1084	6500	>80	3	23.5	250	5.9	184
PL-LIN-Z5 2000-830 280X20-LV/HV	1963	3000	>80	3	43.1	275	11.8	165
PL-LIN-Z5 2000-840 280X20-LV/HV	2072	4000	>80	3	43.1	275	11.8	175
PL-LIN-Z5 2000-865 280X20-LV/HV	2072	6500	>80	3	43.1	275	11.8	175
PL-LIN-Z5 2200-830 560X20-LV	2054	3000	>80	3	23.5	500	11.8	174
PL-LIN-Z5 2200-840 560X20-LV	2168	4000	>80	3	23.5	500	11.8	184
PL-LIN-Z5 2200-865 560X20-LV	2168	6500	>80	3	23.5	500	11.8	184
PL-LIN-Z5 2200-830 560X20-HV	2054	3000	>80	3	47.1	250	11.8	175
PL-LIN-Z5 2200-840 560X20-HV	2168	4000	>80	3	47.1	250	11.8	184
PL-LIN-Z5 2200-865 560X20-HV	2168	6500	>80	3	47.1	250	11.8	184
PL-LIN-Z5 4000-830 560X20-LV	3926	3000	>80	3	43.1	550	23.7	165
PL-LIN-Z5 4000-840 560X20-LV	4156	4000	>80	3	43.1	550	23.7	175
PL-LIN-Z5 4000-865 560X20-LV	4156	6500	>80	3	43.1	550	23.7	175
PL-LIN-Z5 4000-830 560X20-HV	3926	3000	>80	3	86.2	275	23.7	165
PL-LIN-Z5 4000-840 560X20-HV	4145	4000	>80	3	86.2	275	23.7	175
PL-LIN-Z5 4000-865 560X20-HV	4145	6500	>80	3	86.2	275	23.7	175
PL-LIN-Z5 4400-830 1120X20-HV	4107	3000	>80	3	94.2	250	23.5	174
PL-LIN-Z5 4400-840 1120X20-HV	4355	4000	>80	3	94.2	250	23.5	184
PL-LIN-Z5 5500-830 1400X20-HV	5134	3000	>80	3	117.7	250	29.4	174
PL-LIN-Z5 5500-840 1400X20-HV	5419	4000	>80	3	117.7	250	29.4	184

\* Typical value; tolerance for optical and electrical data: ±10 %

#### Nominal current Linear G6, CRI > 90

Product name 20-mm module – CRI > 90	Flux [lm]*	CCT [K]	CRI	SDCM	Voltage [V]	Current [mA]	Power [W]*	Efficacy [lm/W]*
PL-LIN-Z6 245-930 62x20-HV	231	3000	>90	3	5.3	300	1.6	145
PL-LIN-Z6 245-940 62x20-HV	261	4000	>90	3	5.3	300	1.6	164
PL-LIN-Z6 275-930 70x20-LV	260	3000	>90	3	23.8	75	1.8	145
PL-LIN-Z6 275-940 70x20-LV	293	4000	>90	3	23.8	75	1.8	164
PL-LIN-Z6 1100-930 280X20-LV/HV	1039	3000	>90	3	23.8	300	7.2	145
PL-LIN-Z6 1100-940 280X20-LV/HV	1173	4000	>90	3	23.8	300	7.2	164
PL-LIN-Z6 1100-950 280X20-LV/HV	1173	5000	>90	3	23.8	300	7.2	164
PL-LIN-Z6 2000-930 280X20-LV/HV	1821	3000	>90	3	43.2	300	13.0	140
PL-LIN-Z6 2000-940 280X20-LV/HV	2056	4000	>90	3	43.2	300	13.0	158
PL-LIN-Z6 2000-950 280X20-LV/HV	2056	5000	>90	3	43.2	300	13.0	158
PL-LIN-Z6 2200-930 560X20-LV	2079	3000	>90	3	23.8	600	14.3	145
PL-LIN-Z6 2200-940 560X20-LV	2347	4000	>90	3	23.8	600	14.3	164
PL-LIN-Z6 2200-950 560X20-LV	2347	5000	>90	3	23.8	600	14.3	164
PL-LIN-Z6 2200-930 560X20-HV	2079	3000	>90	3	47.7	300	14.3	145
PL-LIN-Z6 2200-940 560X20-HV	2347	4000	>90	3	47.7	300	14.3	164
PL-LIN-Z6 2200-950 560X20-HV	2347	5000	>90	3	47.7	300	14.3	164
PL-LIN-Z6 4000-930 560X20-LV	3641	3000	>90	3	43.2	600	26.0	140
PL-LIN-Z6 4000-940 560X20-LV	4111	4000	>90	3	43.2	600	26.0	158
PL-LIN-Z6 4000-950 560X20-LV	4111	5000	>90	3	43.2	600	26.0	158
PL-LIN-Z6 4000-930 560X20-HV	3641	3000	>90	3	86.5	300	26.0	140
PL-LIN-Z6 4000-940 560X20-HV	4111	4000	>90	3	86.5	300	26.0	158
PL-LIN-Z6 4000-950 560X20-HV	4111	5000	>90	3	86.5	300	26.0	158

\* Typical value; tolerance for optical and electrical data: ±10 %

## Nominal current Linear G6

Product name 20-mm module – CRI >80	Flux [lm]*	CCT [K]	CRI	SDCM	Voltage [V]	Current [mA]	Power [W]*	Efficacy [lm/W]*
PL-LIN-Z6 245-830 62x20-HV	238	3000	>80	3	5.2	250	1.3	181
PL-LIN-Z6 245-840 62x20-HV	257	4000	>80	3	5.2	250	1.3	196
PL-LIN-Z6 275-827 70X20-LV	258	2700	>80	3	23.6	62	1.5	177
PL-LIN-Z6 275-830 70X20-LV	265	3000	>80	3	23.6	62	1.5	181
PL-LIN-Z6 275-840 70X20-LV	286	4000	>80	3	23.6	62	1.5	196
PL-LIN-Z6 550-827 140X20-LV	521	2700	>80	3	23.6	125	3.0	177
PL-LIN-Z6 550-830 140X20-LV	535	3000	>80	3	23.6	125	3.0	181
PL-LIN-Z6 550-840 140X20-LV	577	4000	>80	3	23.6	125	3.0	196
PL-LIN-Z6 550-850 140X20-LV	577	5000	>80	3	23.6	125	3.0	196
PL-LIN-Z6 550-865 140X20-LV	577	6500	>80	3	23.6	125	3.0	196
PL-LIN-Z6 1100-827 280X20-LV/HV	1042	2700	>80	3	23.6	250	5.9	177
PL-LIN-Z6 1100-830 280X20-LV/HV	1070	3000	>80	3	23.6	250	5.9	181
PL-LIN-Z6 1100-840 280X20-LV/HV	1154	4000	>80	3	23.6	250	5.9	196
PL-LIN-Z6 1100-850 280X20-LV/HV	1154	5000	>80	3	23.6	250	5.9	196
PL-LIN-Z6 1100-865 280X20-LV/HV	1154	6500	>80	3	23.6	250	5.9	196
PL-LIN-Z6 2000-827 280X20-LV/HV	1829	2700	>80	3	42.7	250	10.6	171
PL-LIN-Z6 2000-830 280X20-LV/HV	1878	3000	>80	3	42.7	250	10.6	176
PL-LIN-Z6 2000-840 280X20-LV/HV	2026	4000	>80	3	42.7	250	10.6	190
PL-LIN-Z6 2000-850 280X20-LV/HV	2026	5000	>80	3	42.7	250	10.6	190
PL-LIN-Z6 2000-865 280X20-LV/HV	2026	6500	>80	3	42.7	250	10.6	190
PL-LIN-Z6 2200-827 560X20-LV	2083	2700	>80	3	23.6	500	11.8	177
PL-LIN-Z6 2200-830 560X20-LV	2140	3000	>80	3	23.6	500	11.8	181
PL-LIN-Z6 2200-840 560X20-LV	2309	4000	>80	3	23.6	500	11.8	196
PL-LIN-Z6 2200-850 560X20-LV	2309	5000	>80	3	23.6	500	11.8	196
PL-LIN-Z6 2200-865 560X20-LV	2309	6500	>80	3	23.6	500	11.8	196
PL-LIN-Z6 2200-827 560X20-HV	2083	2700	>80	3	47.1	250	11.8	177
PL-LIN-Z6 2200-830 560X20-HV	2140	3000	>80	3	47.1	250	11.8	181
PL-LIN-Z6 2200-840 560X20-HV	2309	4000	>80	3	47.1	250	11.8	196
PL-LIN-Z6 2200-850 560X20-HV	2309	5000	>80	3	47.1	250	11.8	196
PL-LIN-Z6 2200-865 560X20-HV	2309	6500	>80	3	47.1	250	11.8	196
PL-LIN-Z6 4000-827 560X20-LV	3657	2700	>80	3	42.7	500	21.3	171
PL-LIN-Z6 4000-830 560X20-LV	3756	3000	>80	3	42.7	500	21.3	176
PL-LIN-Z6 4000-840 560X20-LV	4053	4000	>80	3	42.7	500	21.3	190
PL-LIN-Z6 4000-850 560X20-LV	4053	5000	>80	3	42.7	500	21.3	190
PL-LIN-Z6 4000-865 560X20-LV	4053	6500	>80	3	42.7	500	21.3	190
PL-LIN-Z6 4000-827 560X20-HV	3657	2700	>80	3	85.3	250	21.3	171
PL-LIN-Z6 4000-830 560X20-HV	3756	3000	>80	3	85.3	250	21.3	176
PL-LIN-Z6 4000-840 560X20-HV	4053	4000	>80	3	85.3	250	21.3	190
PL-LIN-Z6 4000-850 560X20-HV	4053	5000	>80	3	85.3	250	21.3	190
PL-LIN-Z6 4000-865 560X20-HV	4053	6500	>80	3	85.3	250	21.3	190

Due to the special conditions of the manufacturing processes of LEDs, the typical data of technical parameters can only reflect statistical figures and do not necessarily correspond to the actual parameters of each single product which can differ from the typical data.

\* Typical value; tolerance for optical and electrical data:  $\pm 10\%$

## Maximum current Linear G5

Product name 20-mm module – CRI >80	Flux [lm]*	CCT [K]	CRI	SDCM	Voltage [V]	Current [mA]	Power [W]*	Efficacy [lm/W]*
PL-LIN-Z5 1100-830 280X20-LV/HV	1962	3000	>80	3	25.0	500	12.5	157
PL-LIN-Z5 1100-840 280X20-LV/HV	2071	4000	>80	3	25.0	500	12.5	166
PL-LIN-Z5 1100-865 280X20-LV/HV	2071	6500	>80	3	25.0	500	12.5	166
PL-LIN-Z5 2000-830 280X20-LV/HV	2616	3000	>80	3	44.4	375	16.6	157
PL-LIN-Z5 2000-840 280X20-LV/HV	2762	4000	>80	3	44.4	375	16.6	166
PL-LIN-Z5 2000-865 280X20-LV/HV	2762	6500	>80	3	44.4	375	16.6	166
PL-LIN-Z5 2200-830 560X20-LV	3925	3000	>80	3	25.0	1000	25.0	157
PL-LIN-Z5 2200-840 560X20-LV	4143	4000	>80	3	25.0	1000	25.0	166
PL-LIN-Z5 2200-865 560X20-LV	4143	6500	>80	3	25.0	1000	25.0	166
PL-LIN-Z5 2200-830 560X20-HV	3925	3000	>80	3	50.0	500	25.0	157
PL-LIN-Z5 2200-840 560X20-HV	4143	4000	>80	3	50.0	500	25.0	166
PL-LIN-Z5 2200-865 560X20-HV	4143	6500	>80	3	50.0	500	25.0	166
PL-LIN-Z5 4000-830 560X20-LV	5233	3000	>80	3	44.4	750	33.3	157
PL-LIN-Z5 4000-840 560X20-LV	5524	4000	>80	3	44.4	750	33.3	166
PL-LIN-Z5 4000-865 560X20-LV	5524	6500	>80	3	44.4	750	33.3	166
PL-LIN-Z5 4000-830 560X20-HV	5233	3000	>80	3	88.8	375	33.3	157
PL-LIN-Z5 4000-840 560X20-HV	5524	4000	>80	3	88.8	375	33.3	166
PL-LIN-Z5 4000-865 560X20-HV	5524	6500	>80	3	88.8	375	33.3	166
PL-LIN-Z5 4400-830 1120X20-HV	7849	3000	>80	3	100.0	500	50.0	157
PL-LIN-Z5 4400-840 1120X20-HV	8285	4000	>80	3	100.0	500	50.0	165
PL-LIN-Z5 5500-830 1400X20-HV	9812	3000	>80	3	125.0	500	62.4	157
PL-LIN-Z5 5500-840 1400X20-HV	10357	4000	>80	3	125.0	500	62.4	166

\* Typical value; tolerance for optical and electrical data: ±10 %

**Maximum current Linear G6, CRI > 90**

Product name 20-mm module – CRI > 90	Flux [lm]*	CCT [K]	CRI	SDCM	Voltage [V]	Current [mA]	Power [W]*	Efficacy [lm/W]*
PL-LIN-Z6 245-930 62x20-HV	442	3000	>90	3	5.6	600	3.4	131
PL-LIN-Z6 245-940 62x20-HV	499	4000	>90	3	5.6	600	3.4	148
PL-LIN-Z6 275-930 70x20-LV	497	3000	>90	3	25.2	150	3.8	131
PL-LIN-Z6 275-940 70x20-LV	562	4000	>90	3	25.2	150	3.8	148
PL-LIN-Z6 1100-930 280X20-LV/HV	1990	3000	>90	3	25.2	600	15.1	131
PL-LIN-Z6 1100-940 280X20-LV/HV	2247	4000	>90	3	25.2	600	15.1	148
PL-LIN-Z6 1100-950 280X20-LV/HV	2247	5000	>90	3	25.2	600	15.1	148
PL-LIN-Z6 2000-930 280X20-LV/HV	2653	3000	>90	3	44.9	450	20.2	131
PL-LIN-Z6 2000-940 280X20-LV/HV	2995	4000	>90	3	44.9	450	20.2	148
PL-LIN-Z6 2000-950 280X20-LV/HV	2995	5000	>90	3	44.9	450	20.2	148
PL-LIN-Z6 2200-930 560X20-LV	3980	3000	>90	3	25.2	1200	30.3	131
PL-LIN-Z6 2200-940 560X20-LV	4493	4000	>90	3	25.2	1200	30.3	148
PL-LIN-Z6 2200-950 560X20-LV	4493	5000	>90	3	25.2	1200	30.3	148
PL-LIN-Z6 2200-930 560X20-HV	3980	3000	>90	3	50.5	600	30.3	131
PL-LIN-Z6 2200-940 560X20-HV	4493	4000	>90	3	50.5	600	30.3	148
PL-LIN-Z6 2200-950 560X20-HV	4493	5000	>90	3	50.5	600	30.3	148
PL-LIN-Z6 4000-930 560X20-LV	5306	3000	>90	3	44.9	900	40.4	131
PL-LIN-Z6 4000-940 560X20-LV	5991	4000	>90	3	44.9	900	40.4	148
PL-LIN-Z6 4000-950 560X20-LV	5991	5000	>90	3	44.9	900	40.4	148
PL-LIN-Z6 4000-930 560X20-HV	5306	3000	>90	3	89.8	450	40.4	131
PL-LIN-Z6 4000-940 560X20-HV	5991	4000	>90	3	89.8	450	40.4	148
PL-LIN-Z6 4000-950 560X20-HV	5991	5000	>90	3	89.8	450	40.4	148

Typical values valid for  $T_p = 50^\circ\text{C}$

Energy Efficiency Class according to 2012/874/EC: A++

Due to the special conditions of the manufacturing processes of LEDs, the typical data of technical parameters can only reflect statistical figures and do not necessarily correspond to the actual parameters of each single product which can differ from the typical data.

\* Tolerance for optical and electrical data:  $\pm 10\%$

**Maximum current Linear G6**

Product name 20-mm module – CRI >80	Flux [lm]*	CCT [K]	CRI	SDCM	Voltage [V]	Current [mA]	Power [W]*	Efficacy [lm/W]*
PL-LIN-Z6 245-830 62x20-HV	458	3000	> 80	3	5.5	500	2.7	166
PL-LIN-Z6 245-840 62x20-HV	494	4000	> 80	3	5.5	500	2.7	179
PL-LIN-Z6 275-827 70X20-LV	502	2700	> 80	3	24.8	125	3.1	162
PL-LIN-Z6 275-830 70X20-LV	516	3000	> 80	3	24.8	125	3.1	166
PL-LIN-Z6 275-840 70X20-LV	556	4000	> 80	3	24.8	125	3.1	179
PL-LIN-Z6 550-827 140X20-LV	1004	2700	> 80	3	24.8	250	6.2	162
PL-LIN-Z6 550-830 140X20-LV	1031	3000	> 80	3	24.8	250	6.2	166
PL-LIN-Z6 550-840 140X20-LV	1113	4000	> 80	3	24.8	250	6.2	179
PL-LIN-Z6 550-850 140X20-LV	1113	5000	> 80	3	24.8	250	6.2	179
PL-LIN-Z6 550-865 140X20-LV	1113	6500	> 80	3	24.8	250	6.2	179
PL-LIN-Z6 1100-827 280X20-LV/HV	2008	2700	> 80	3	24.8	500	12.4	162
PL-LIN-Z6 1100-830 280X20-LV/HV	2062	3000	> 80	3	24.8	500	12.4	166
PL-LIN-Z6 1100-840 280X20-LV/HV	2225	4000	> 80	3	24.8	500	12.4	179
PL-LIN-Z6 1100-850 280X20-LV/HV	2225	5000	> 80	3	24.8	500	12.4	179
PL-LIN-Z6 1100-865 280X20-LV/HV	2225	6500	> 80	3	24.8	500	12.4	179
PL-LIN-Z6 2000-827 280X20-LV/HV	2677	2700	> 80	3	44.1	375	16.5	162
PL-LIN-Z6 2000-830 280X20-LV/HV	2750	3000	> 80	3	44.1	375	16.5	166
PL-LIN-Z6 2000-840 280X20-LV/HV	2967	4000	> 80	3	44.1	375	16.5	179
PL-LIN-Z6 2000-850 280X20-LV/HV	2967	5000	> 80	3	44.1	375	16.5	179
PL-LIN-Z6 2000-865 280X20-LV/HV	2967	6500	> 80	3	44.1	375	16.5	179
PL-LIN-Z6 2200-827 560X20-LV	4016	2700	> 80	3	24.8	1000	24.8	162
PL-LIN-Z6 2200-830 560X20-LV	4124	3000	> 80	3	24.8	1000	24.8	166
PL-LIN-Z6 2200-840 560X20-LV	4450	4000	> 80	3	24.8	1000	24.8	179
PL-LIN-Z6 2200-850 560X20-LV	4450	5000	> 80	3	24.8	1000	24.8	179
PL-LIN-Z6 2200-865 560X20-LV	4450	6500	> 80	3	24.8	1000	24.8	179
PL-LIN-Z6 2200-827 560X20-HV	4016	2700	> 80	3	49.6	500	24.8	162
PL-LIN-Z6 2200-830 560X20-HV	4124	3000	> 80	3	49.6	500	24.8	166
PL-LIN-Z6 2200-840 560X20-HV	4450	4000	> 80	3	49.6	500	24.8	179
PL-LIN-Z6 2200-850 560X20-HV	4450	5000	> 80	3	49.6	500	24.8	179
PL-LIN-Z6 2200-865 560X20-HV	4450	6500	> 80	3	49.6	500	24.8	179
PL-LIN-Z6 4000-827 560X20-LV	5355	2700	> 80	3	44.1	750	33.1	162
PL-LIN-Z6 4000-830 560X20-LV	5499	3000	> 80	3	44.1	750	33.1	166
PL-LIN-Z6 4000-840 560X20-LV	5933	4000	> 80	3	44.1	750	33.1	179
PL-LIN-Z6 4000-850 560X20-LV	5933	5000	> 80	3	44.1	750	33.1	179
PL-LIN-Z6 4000-865 560X20-LV	5933	6500	> 80	3	44.1	750	33.1	179
PL-LIN-Z6 4000-827 560X20-HV	5355	2700	> 80	3	88.2	375	33.1	162
PL-LIN-Z6 4000-830 560X20-HV	5499	3000	> 80	3	88.2	375	33.1	166
PL-LIN-Z6 4000-840 560X20-HV	5933	4000	> 80	3	88.2	375	33.1	179
PL-LIN-Z6 4000-850 560X20-HV	5933	5000	> 80	3	88.2	375	33.1	179
PL-LIN-Z6 4000-865 560X20-HV	5933	6500	> 80	3	88.2	375	33.1	179

\* Typical value; tolerance for optical and electrical data: ±10 %

### 1.6 Luminous flux as a function of forward current

The luminous flux of the LED modules depends on the applied forward current. It is possible, however, to vary between the nominal and absolute maximum current values for each module type and also below the nominal current, e.g. to exactly set a requested value for the luminous flux. The diagrams below show the luminous flux at nominal conditions ( $t_p = 50^\circ\text{C}$ ) for different currents.

#### PL-LIN-Z6

##### 20-mm module, CRI > 80, 275lm (LV)

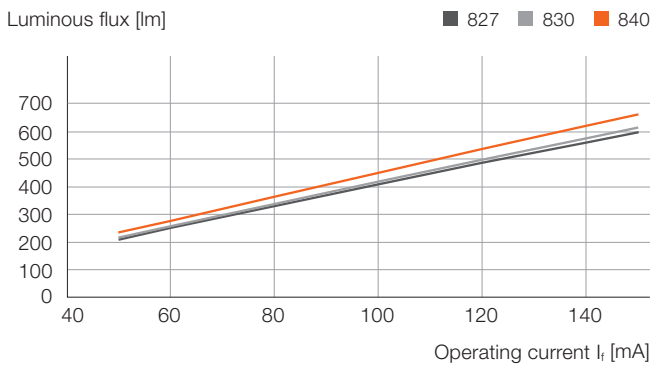

##### 20-mm module, CRI > 80, 245lm (HV)

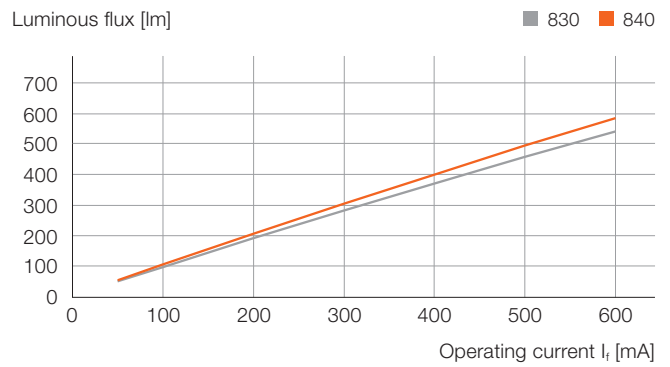

##### 20-mm module, CRI > 80, 550lm (LV)

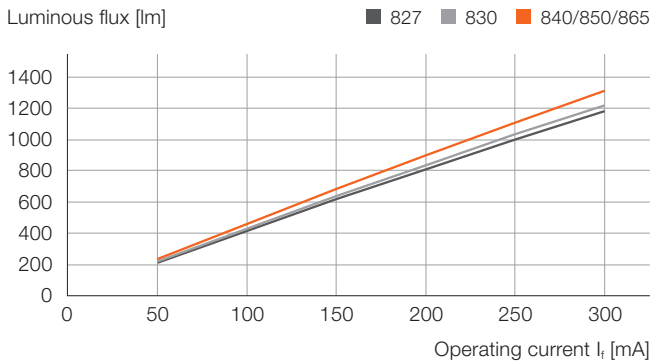

##### 20-mm module, CRI > 80, 1100lm (LV/HV)

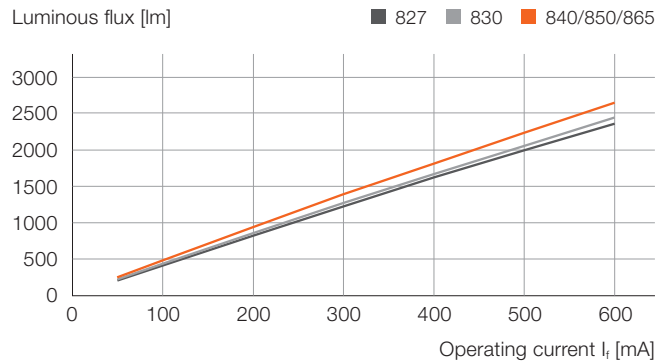

By choosing the requested luminous flux on the y-axis of the diagram, you can derive the needed forward current that has to be applied to the LED module on the x-axis. Needless to say, this also works the other way around: For a set current, you can read the corresponding luminous flux on the y-axis.

**PL-LIN-Z6**

**20-mm module, CRI >80, 2000lm (LV/HV)**

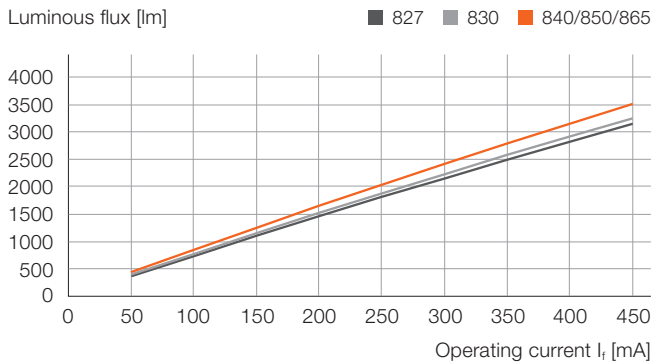

**20-mm module, CRI >80, 2200lm (LV)**

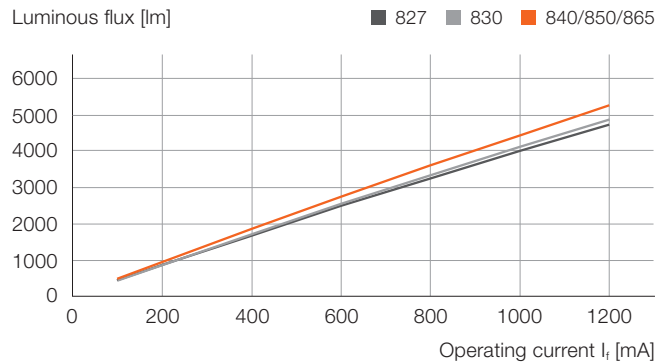

**20-mm module, CRI >80, 4000lm (LV)**

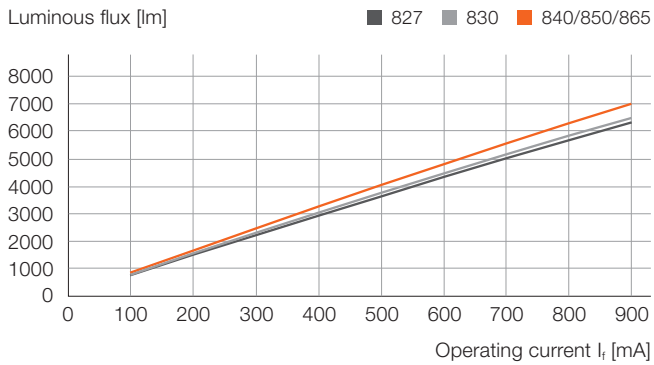

**20-mm module, CRI >80, 2200lm (HV)**

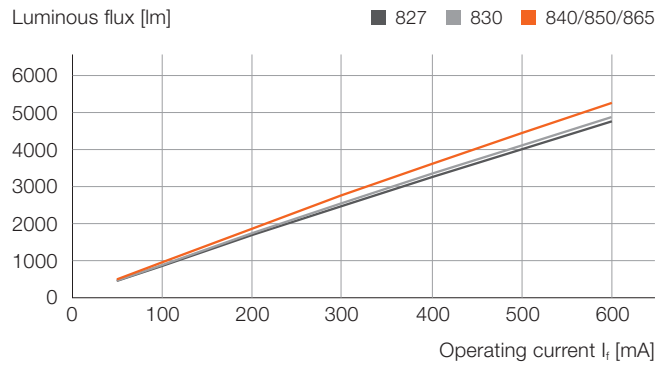

**20-mm module, CRI >80, 4000lm (HV)**

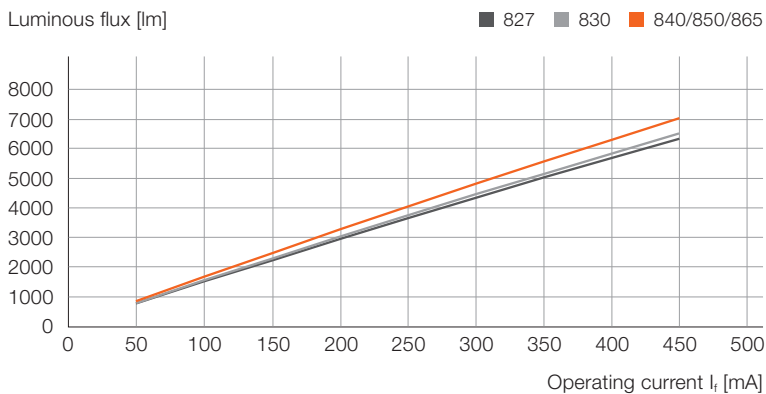

**PL-LIN-Z6, CRI > 90**

**20-mm module, CRI > 90, 275lm (LV)**

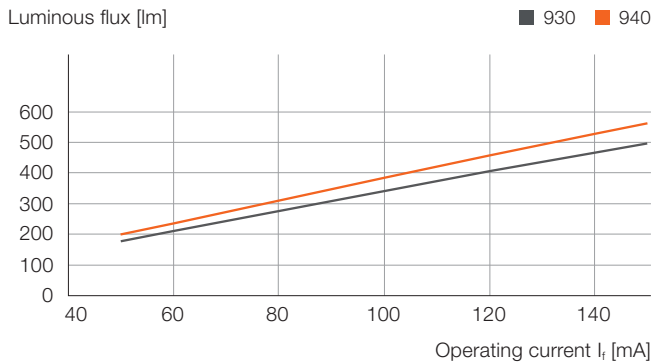

**20-mm module, CRI > 90, 245lm (HV)**

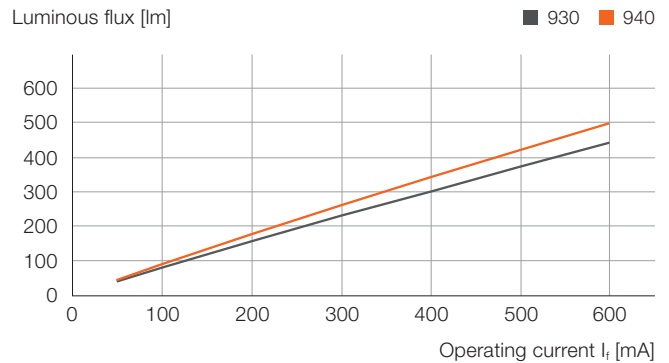

**20-mm module, CRI > 90, 1100lm (LV/HV)**

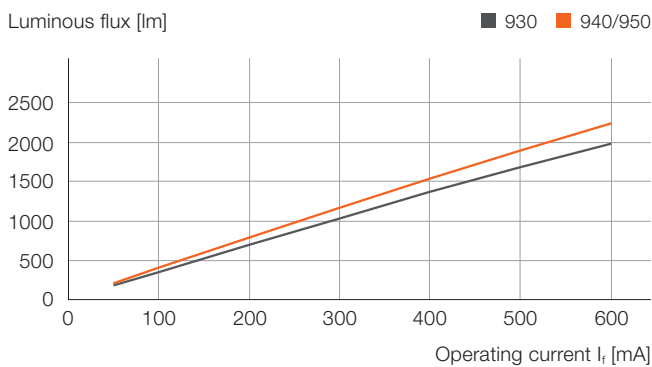

**20-mm module, CRI > 90, 2000lm (LV/HV)**

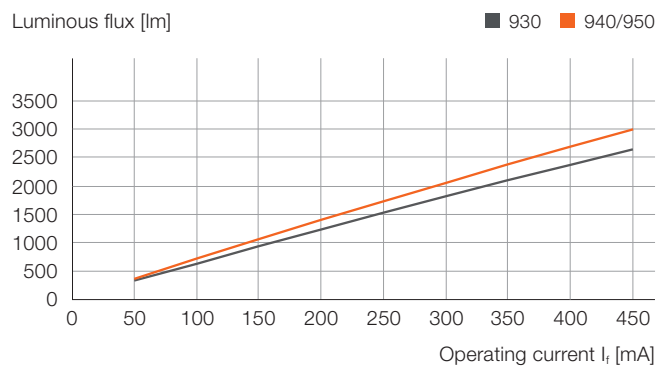

**20-mm module, CRI > 90, 2200lm (LV)**

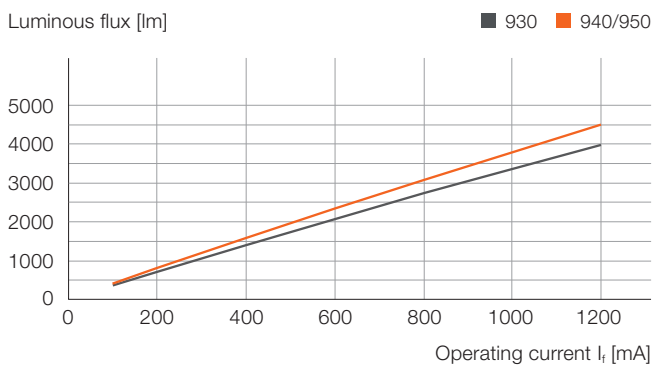

**20-mm module, CRI > 90, 4000lm (LV)**

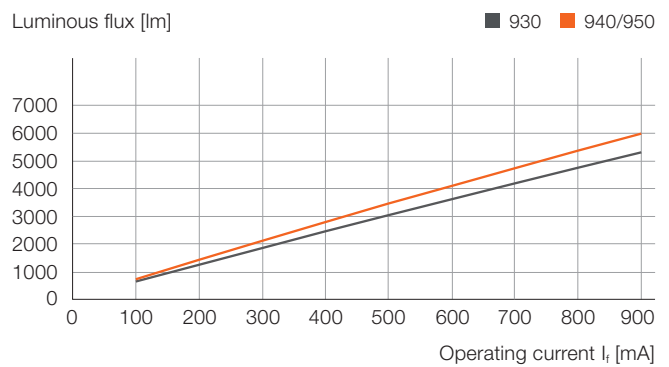

**20-mm module, CRI > 90, 2200lm (HV)**

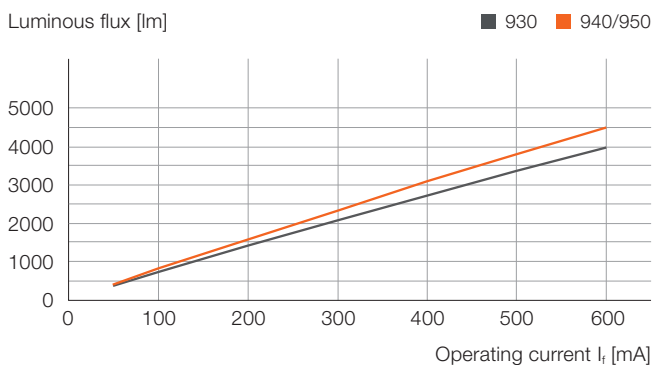

**20-mm module, CRI > 90, 4000lm (HV)**

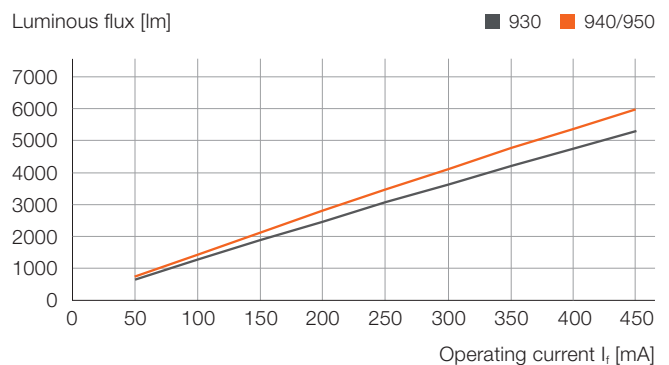

**PL-LIN-Z5**

**20-mm module, CRI >80, 1100lm (LV/HV)**

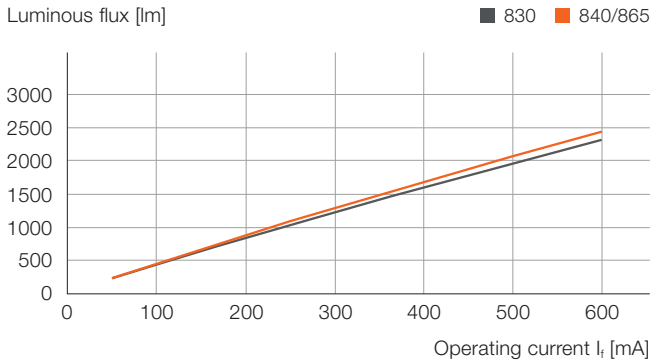

**20-mm module, CRI >80, 2000lm (LV/HV)**

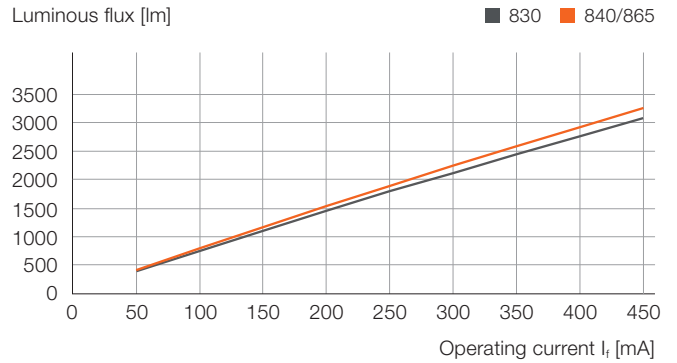

**20-mm module, CRI >80, 2200lm (LV)**

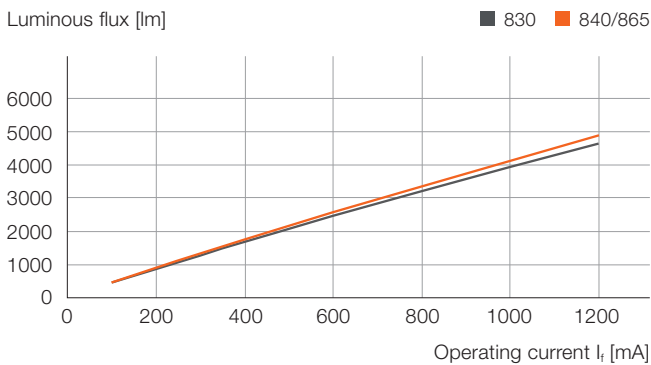

**20-mm module, CRI >80, 4000lm (LV)**

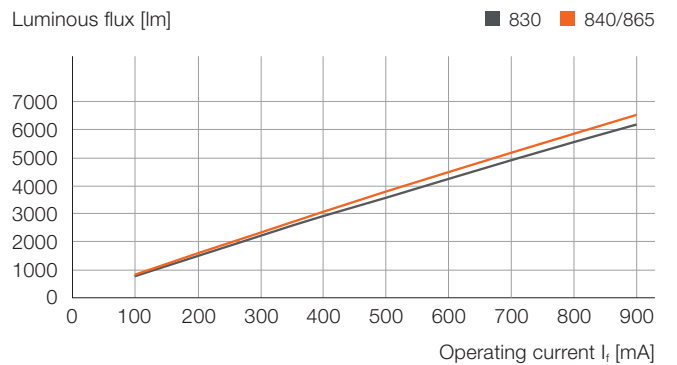

**20-mm module, CRI >80, 2200lm (HV)**

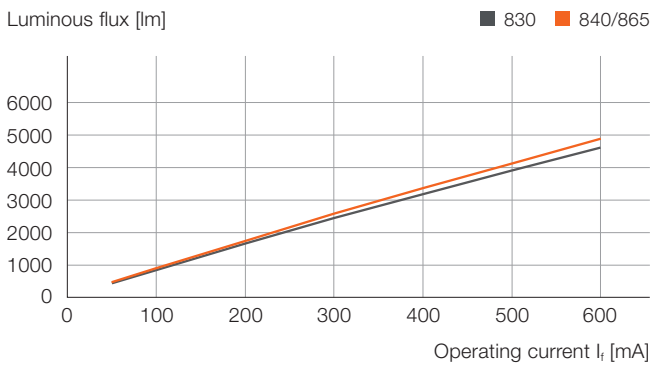

**20-mm module, CRI >80, 4000lm (HV)**

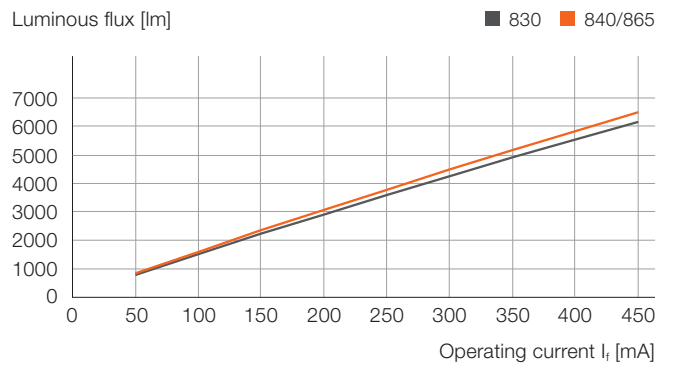

**20-mm module, CRI >80, 4400lm (HV)**

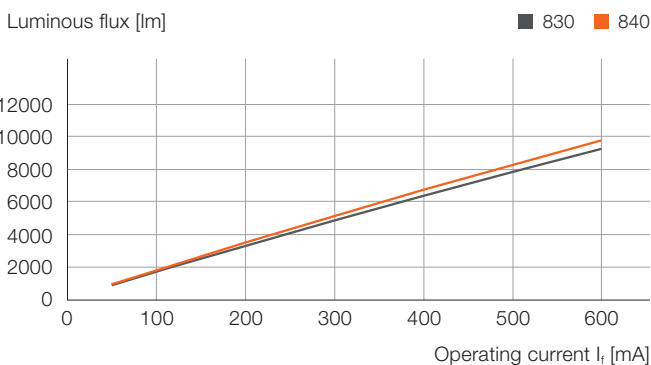

**20-mm module, CRI >80, 5500lm (HV)**

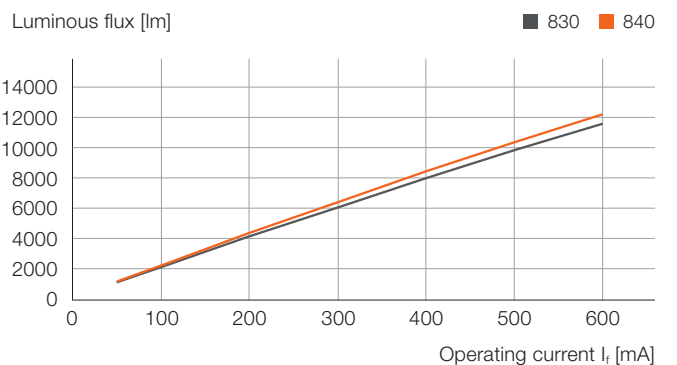

### 1.7 Luminous flux and efficacy as a function of $t_c$ point temperature

All tables and diagrams shown up to now were measured or calculated for a  $t_c$  point temperature of 50 °C, the nominal temperature condition of the PrevaLED® Linear G5/G6 LED modules. It is realistic that the  $t_c$  point temperature in a given luminaire differs from the nominal conditions and that this has an impact on the luminous flux and efficacy.

If the  $t_c$  point temperature on the LED module is lower than the nominal temperature of 50 °C, the relative luminous flux and relative efficacy are increased.

If the  $t_c$  point temperature on the LED module is higher than the nominal temperature of 50 °C, the relative luminous flux and relative efficacy are decreased.

The diagram below shows the correlation between the  $t_c$  point temperature and relative luminous flux/efficacy. Since it shows only relative values, the diagram gives an approximation that can be used for all the different module types (e.g. different color temperatures, different module lengths).\*

#### Luminous flux and efficacy as functions of the $t_c$ point temperature

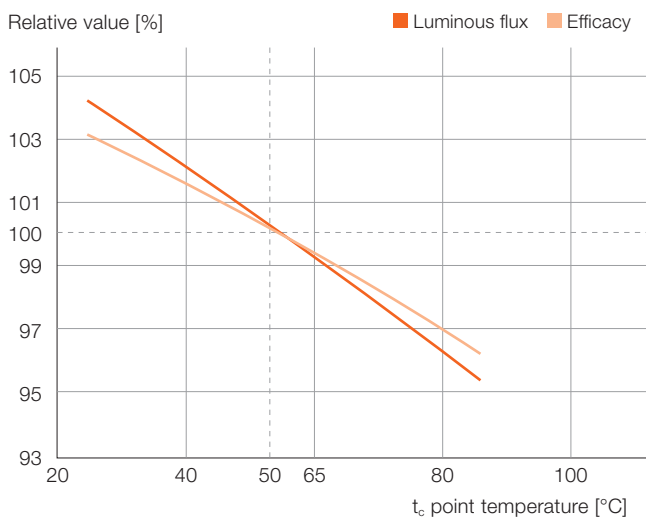

\* All tolerances given in the datasheet of the PrevaLED® Linear G5/G6 LED modules are still valid.

## 2 Optical considerations

### 2.1 Light distribution

The light distribution of PrevaLED® Linear G5/G6 has a Lambertian shape with a beam angle of 120° FWHM (full width at half maximum).

EULUMDAT and IES files can be found on our website at [www.inventronicsglobal.com](http://www.inventronicsglobal.com)

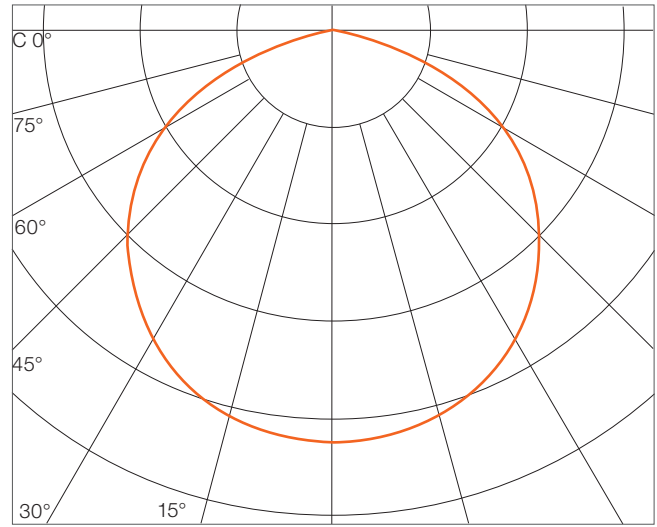

Within each available color temperature, the PrevaLED® Linear G5/G6 series provides a maximum color variation of three threshold value units (MacAdam steps).

### 2.2 Color temperature and coordinates

PrevaLED® Linear G5/G6 is available with color temperatures of 2700 K, 3000 K, 4000 K, 5000 K and 6500 K at CRI > 80 as well as 3000 K, 4000 K and 5000 K at CRI > 90. The color coordinate windows within the CIE 1931 color space are given below.

#### G6, CRI > 80

	2700K	3000K	4000K	5000K	6500K
<b>Cx</b>	0.456	0.43	0.376	0.342	0.306
<b>Cy</b>	0.409	0.4	0.374	0.355	0.319

#### Threshold values within the CIE 1931 color space

##### CRI > 80

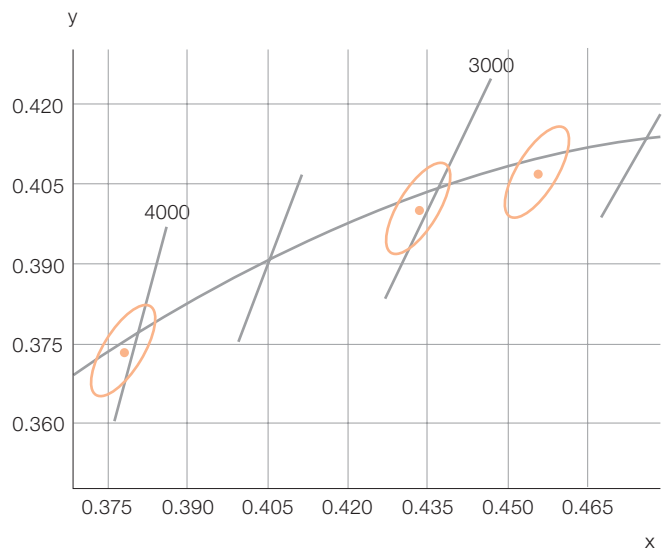
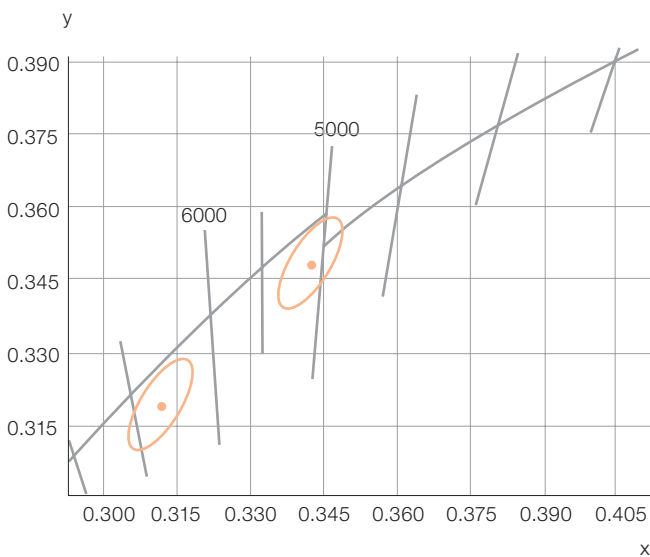

\* All values in this chapter are general values. Values for specific modules may vary from these values. Please refer to the corresponding datasheet.

**G6, CRI > 90**

	3000K	4000K	5000K
<b>Cx</b>	0.427	0.374	0.338
<b>Cy</b>	0.395	0.367	0.347

**Threshold values within the CIE 1931 color space**

**CRI > 90**

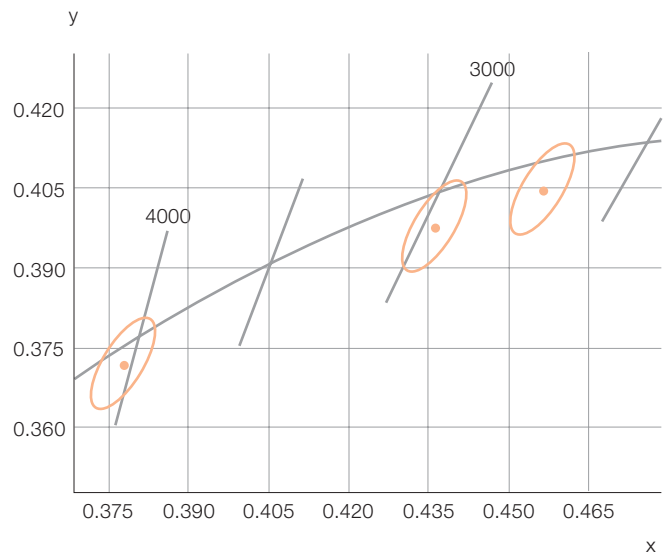
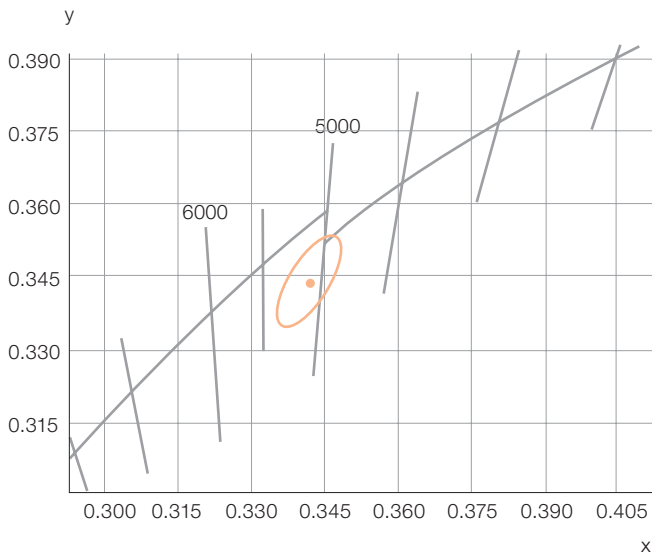

**G5, CRI > 80**

	3000K	4000K	6500K
<b>Cx</b>	0.431	0.379	0.311
<b>Cy</b>	0.398	0.375	0.327

**Threshold values within the CIE 1931 color space**

**CRI > 80**

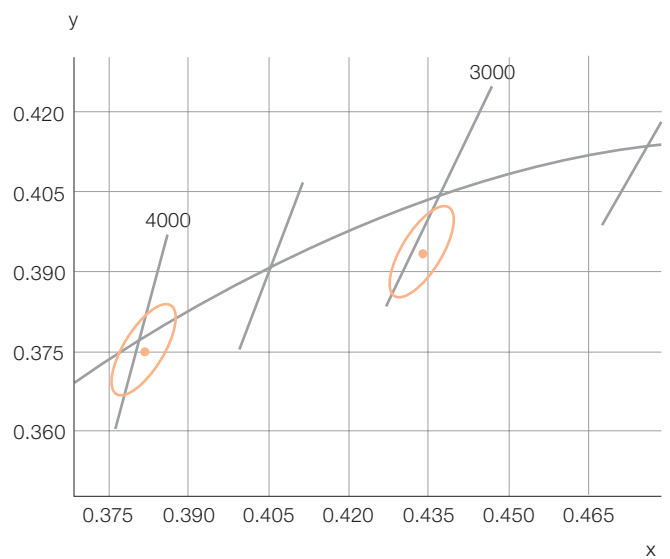
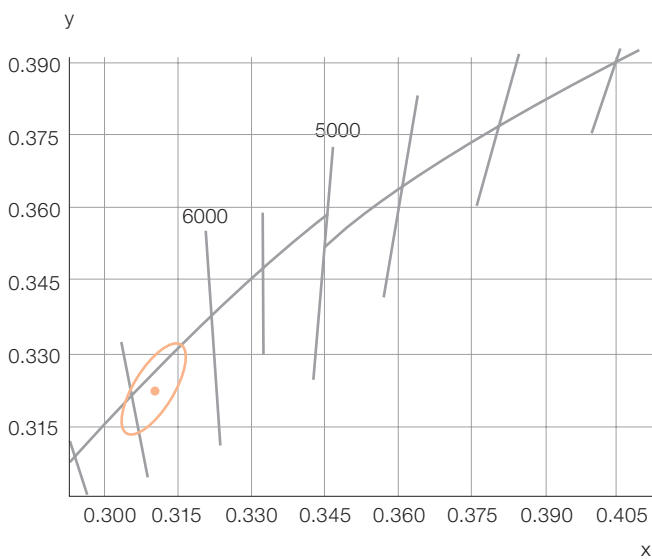

### 2.3 Spectral distribution

The following diagram shows the typical spectral distribution of PrevaLED® Linear G5/G6 LED modules for different available color temperatures.

#### Spectral distribution at PL-LIN-Z6, CRI > 80

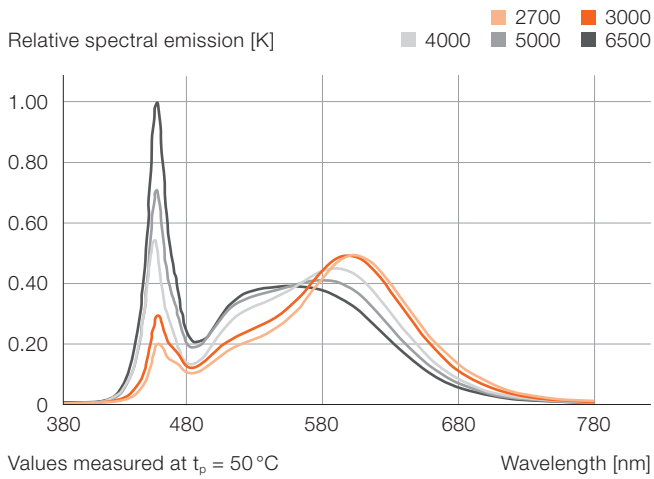

#### Spectral distribution at PL-LIN-Z6, CRI > 90

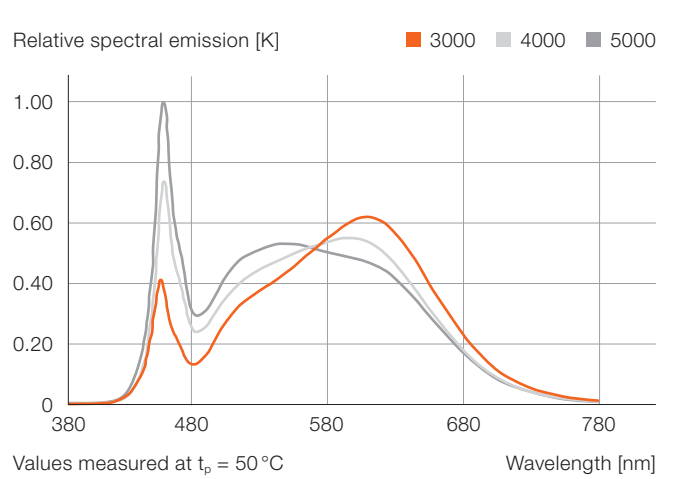

#### Spectral distribution at PL-LIN-Z5

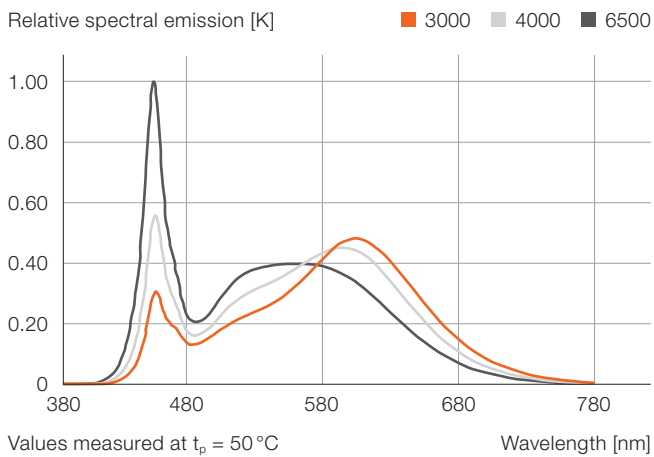

### 2.4 Color rendering

PrevaLED® Linear G5/G6 LED modules provide a color rendering index (CRI) of >80 or >90. The tables below show the individual R<sub>a</sub> values from R1 to R14 for the available color temperatures (measured at nominal current, t<sub>p</sub> = 50 °C).

#### R<sub>a</sub> values for PrevaLED® Linear G6, CRI >80

	Dusky pink	Mustard yellow	Yellowish green	Light green	Turquoise	Azure	Aster violet	Lilac violet	Red, saturated	Yellow, saturated	Green, saturated	Blue, saturated	Pink, skin color	Leaf green	General CRI
	R1	R2	R3	R4	R5	R6	R7	R8	R9	R10	R11	R12	R13	R14	R <sub>a</sub>
<b>CCT = 2700 K</b>	84	94	93	82	85	95	82	60	15	88	83	80	87	97	84
<b>CCT = 3000 K</b>	83	93	95	82	84	93	82	60	12	85	82	75	86	98	84
<b>CCT = 4000 K</b>	81	89	94	93	82	85	86	65	8	74	82	63	83	97	83
<b>CCT = 5000 K</b>	82	90	94	83	83	85	88	68	10	75	83	62	85	97	84
<b>CCT = 6500 K</b>	83	89	90	84	83	83	89	73	15	72	83	56	85	95	84

#### R<sub>a</sub> values for PrevaLED® Linear G6, CRI >90

	Dusky pink	Mustard yellow	Yellowish green	Light green	Turquoise	Azure	Aster violet	Lilac violet	Red, saturated	Yellow, saturated	Green, saturated	Blue, saturated	Pink, skin color	Leaf green	General CRI
	R1	R2	R3	R4	R5	R6	R7	R8	R9	R10	R11	R12	R13	R14	R <sub>a</sub>
<b>CCT = 3000 K</b>	93	95	95	93	93	93	93	85	65	88	93	80	93	97	92
<b>CCT = 4000 K</b>	93	97	97	92	92	93	93	86	67	91	92	71	95	98	93
<b>CCT = 5000 K</b>	93	94	93	93	92	90	95	90	70	85	92	69	93	96	92

#### R<sub>a</sub> values for PrevaLED® Linear G5, CRI > 80

	Dusky pink	Mustard yellow	Yellowish green	Light green	Turquoise	Azure	Aster violet	Lilac violet	Red, saturated	Yellow, saturated	Green, saturated	Blue, saturated	Pink, skin color	Leaf green	General CRI
	R1	R2	R3	R4	R5	R6	R7	R8	R9	R10	R11	R12	R13	R14	R <sub>a</sub>
<b>CCT = 3000 K</b>	84	95	93	80	84	94	82	61	15	89	80	74	87	97	84
<b>CCT = 4000 K</b>	82	93	95	79	82	89	84	63	10	83	78	61	86	98	83
<b>CCT = 6500 K</b>	82	90	92	81	81	82	89	71	12	73	80	53	85	96	84

# 3 Electrical considerations

## 3.1 Wiring information

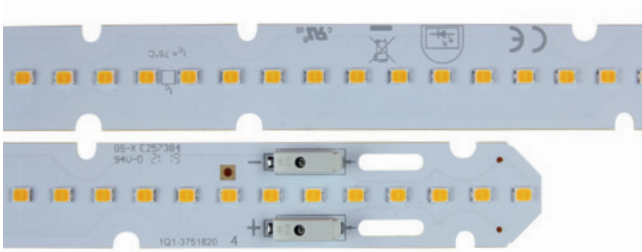

The connector used on the PrevaLED® Linear G5/G6 LED modules (pictured above) can handle solid wires and fine-stranded wires with cross-sections from 0.2 to 0.75 mm<sup>2</sup> (AWG 24–18). The use of solid wires is recommended.

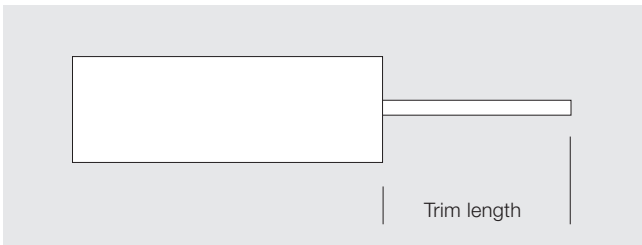

The stripped length is recommended to be 8 to 9 mm. Please insert wires in 0° orientation into the PCB.

PrevaLED® Linear G5/G6 are designed with a cut-out area in front of the connector (see following picture). This allows you to insert the wires into the connector from the back, avoiding unwanted shadowing by the wires.



## 3.2 Disconnecting the wire from the connector

The connector on the PrevaLED® Linear G5/G6 LED module has an easy and simple “poke-in” and release mechanism. Solid wires can simply be plugged into the connector. If fine-stranded wires are used, it is recommended to use the release button on top of the module also for easier insertion. The wires/cables can be removed by pressing the release button on top of the connector and pulling the wires/cables out.

The pictures below show how to disconnect a wire from the connector.

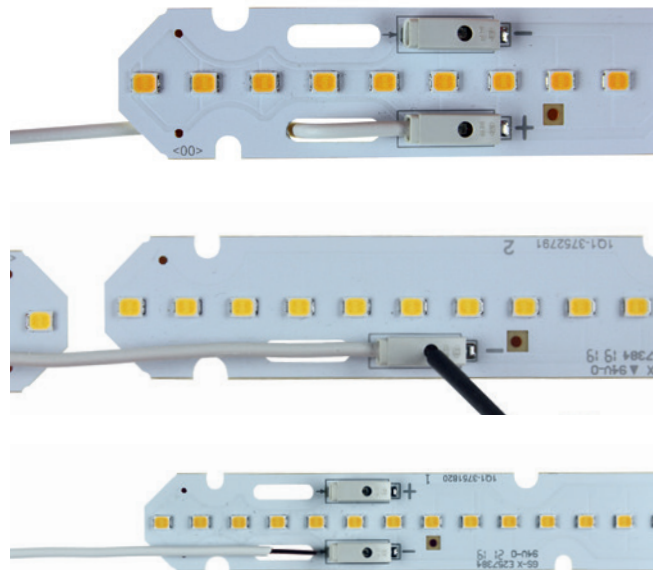

## 3.3 Electrostatic discharge (ESD)

PrevaLED® Linear G5/G6 LED modules fulfill the requirement of the immunity standard IEC/EN 61547. Please note that an electrostatic discharge of more than 2 kV HBM can cause damage, ranging from performance degradation to complete device failure.

We recommend to handle and store all PrevaLED® Linear G5/G6 LED modules using appropriate ESD protection methods.

### 3.4 Forward voltage as a function of forward current\*

The diagrams on the next pages show the relative dependence of the forward voltage ( $V_f$ ) on the forward current ( $I_f$ ) at different temperatures (from 0 °C to 75 °C) for the different PrevaLED® Linear G5/G6 LED modules. They show only the area that is of interest for lighting applications, which is in first approximation linear. The different colors show different  $t_p$  temperatures, the numbers below the diagram represent the scaling for different LED module types (the 550-lm and 650-lm LED modules as well as the 1100-lm and 1300-lm LED modules use the same scale).

---

\* Of course, all tolerances given in the datasheet of the PrevaLED® Linear G5/G6 LED modules are still valid.

**PL-LIN-Z6, 245lm, CRI > 80**

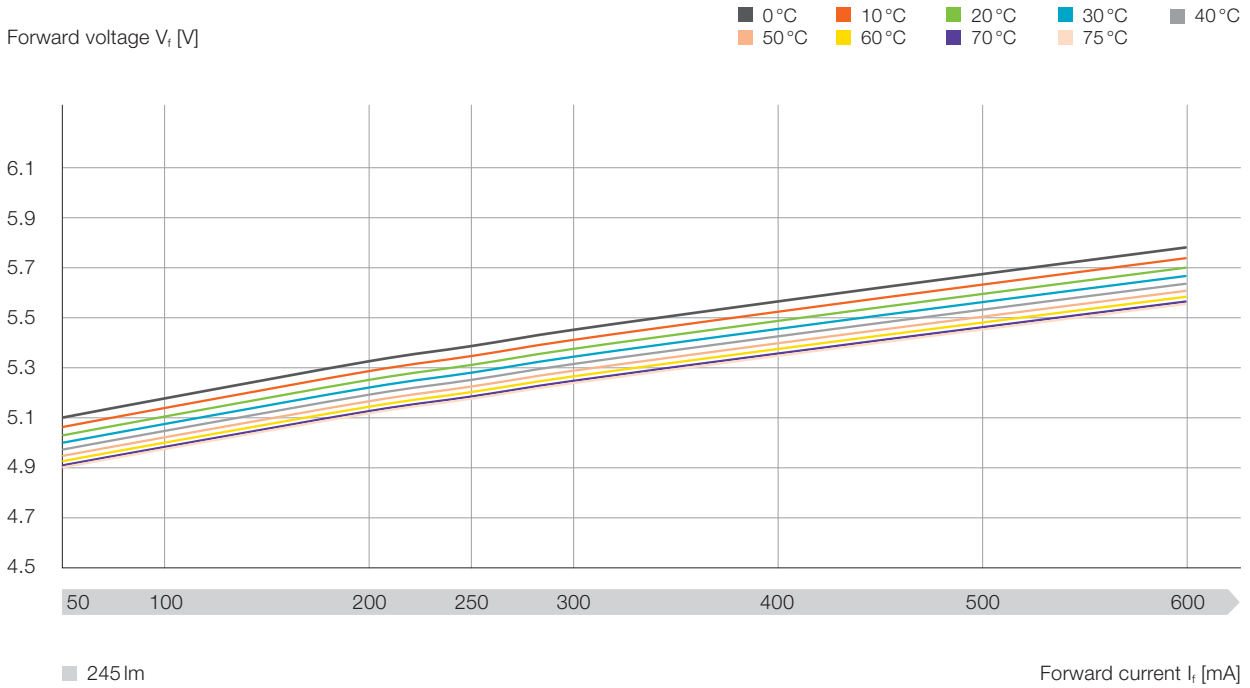

**PL-LIN-Z6, 275lm, 550lm, 1100lm, 2200lm, CRI > 80**

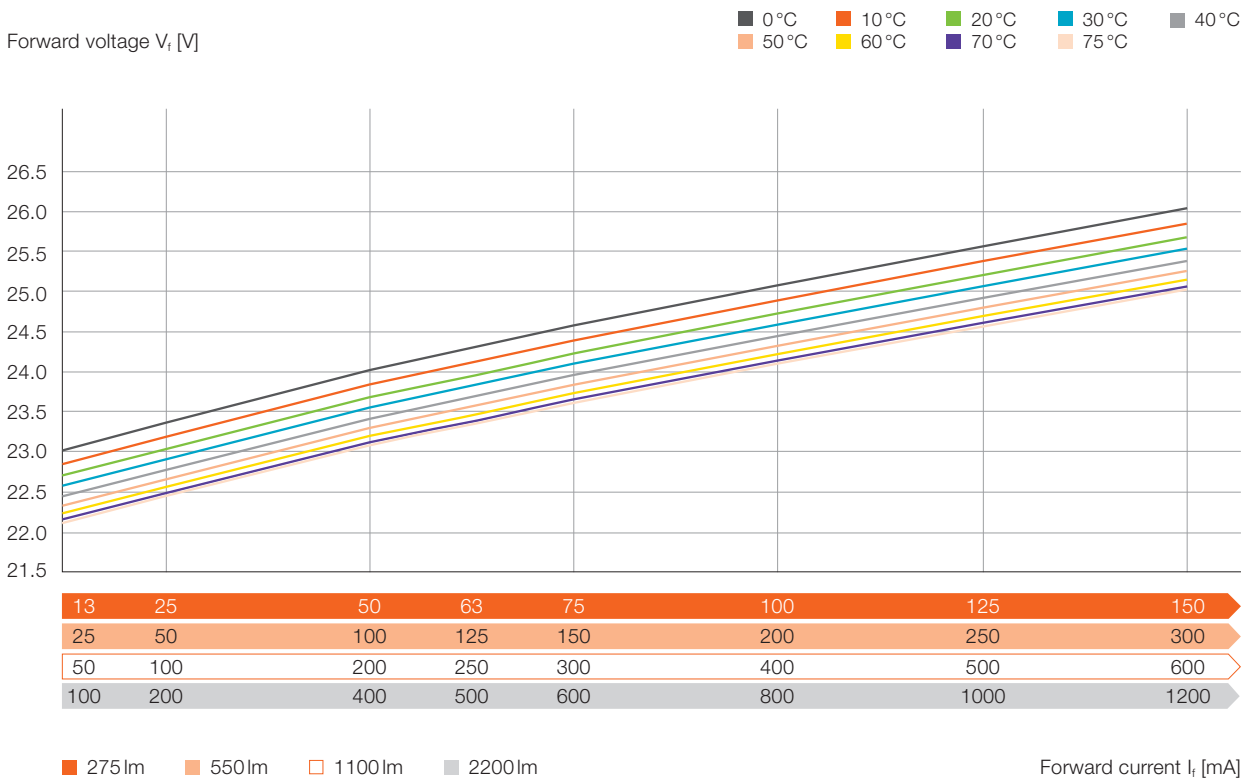

**PL-LIN-Z6, 2000Im, 4000Im, CRI > 80**

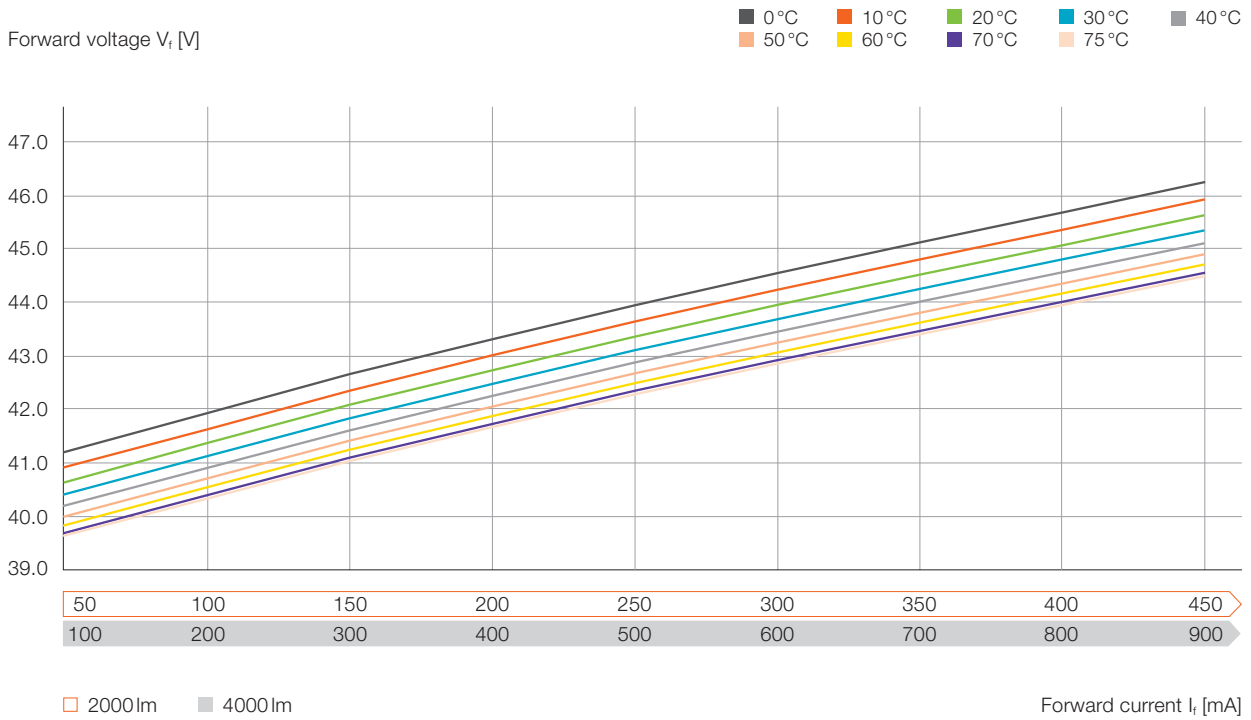

**PL-LIN-Z6, 2200Im, CRI > 80**

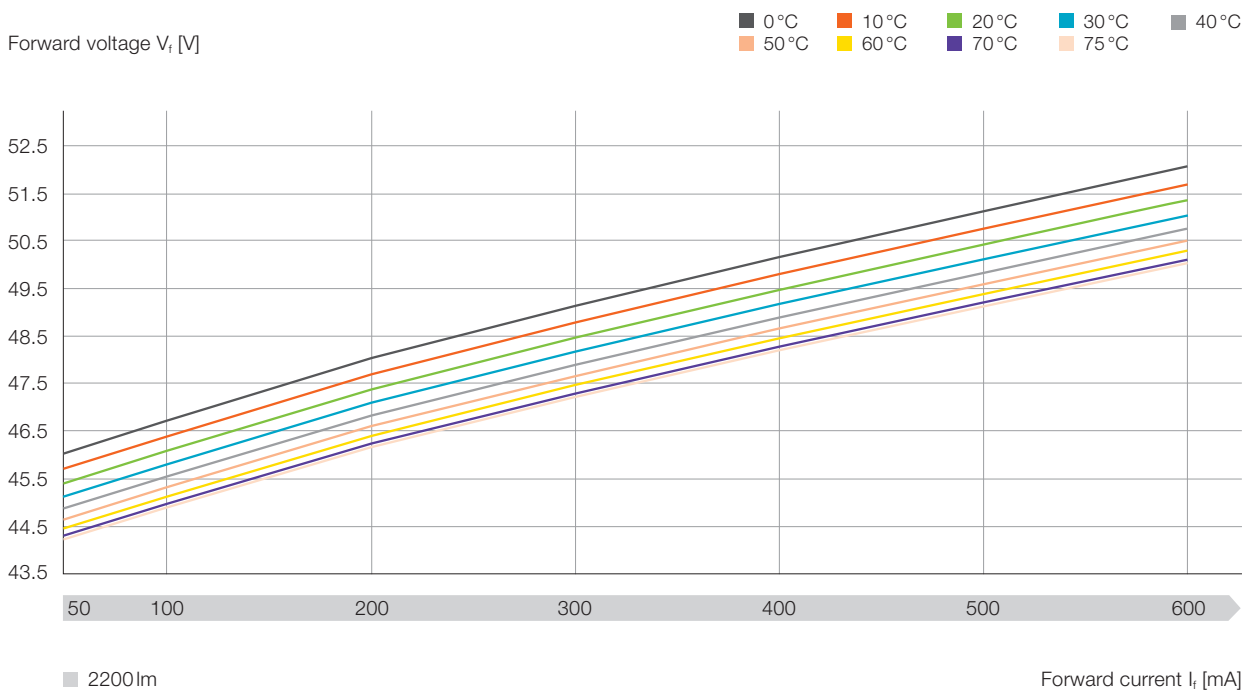

**PL-LIN-Z6, 4000lm, CRI > 80**

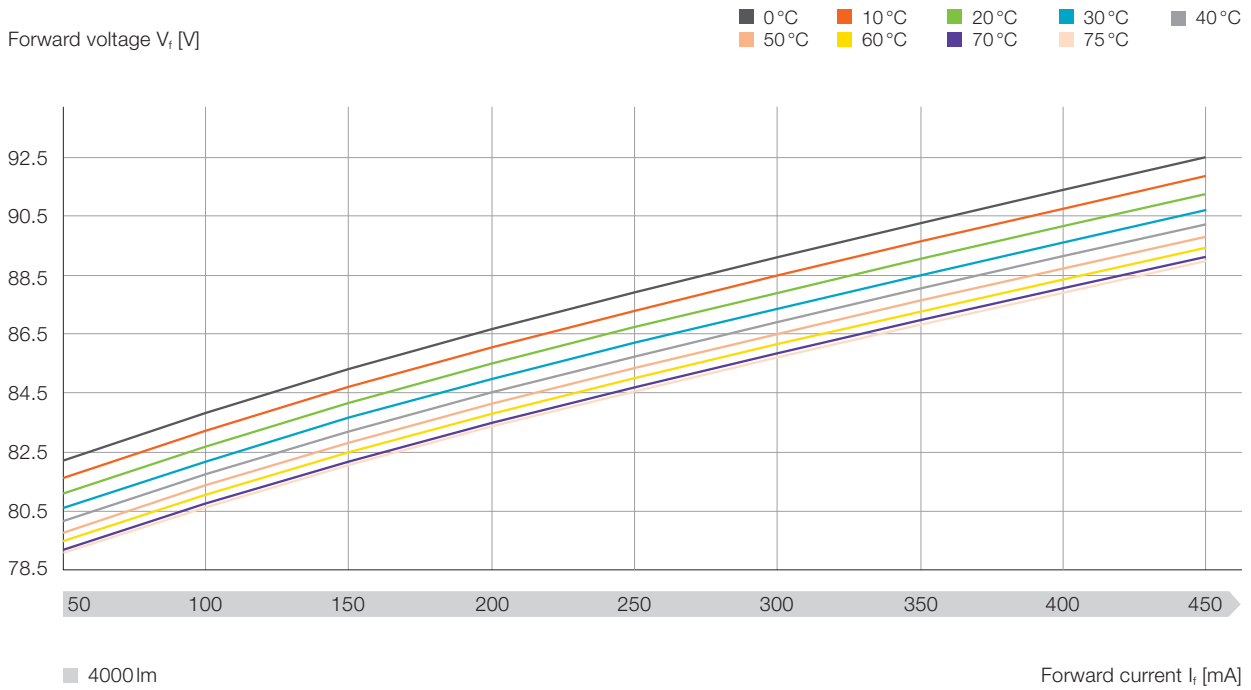

**PL-LIN-Z6, 245lm, CRI > 90**

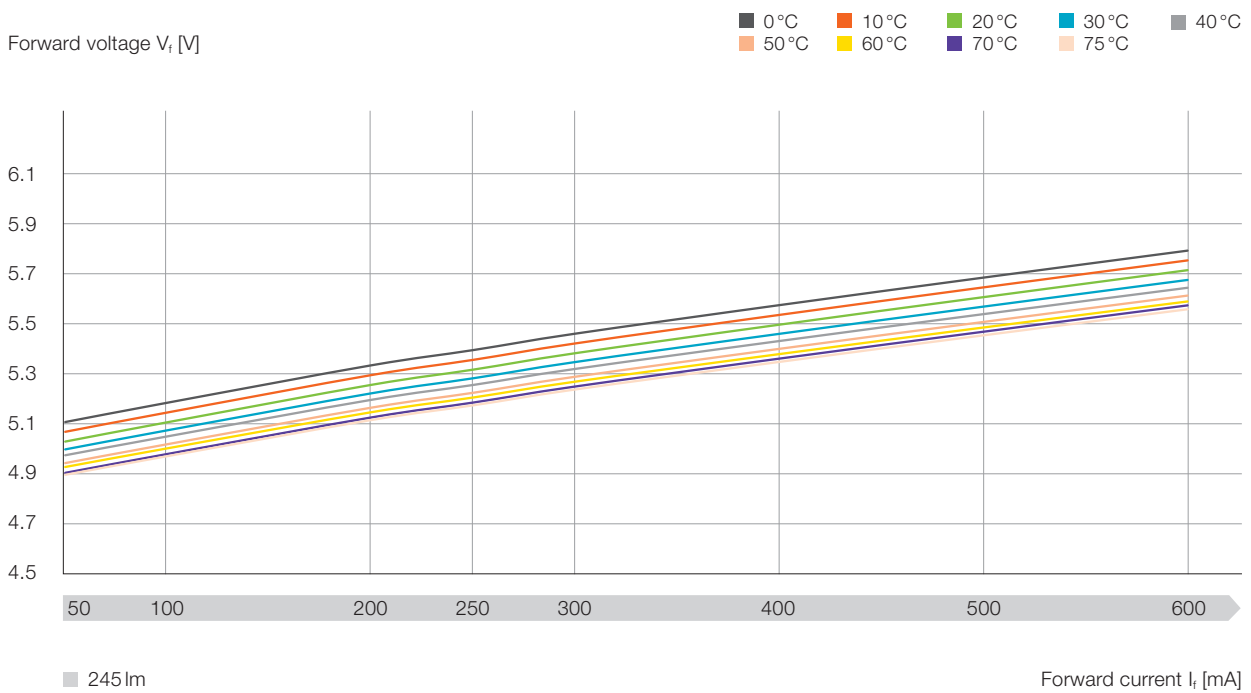

**PL-LIN-Z6, 275lm, 1100lm, 2200lm, CRI > 90**

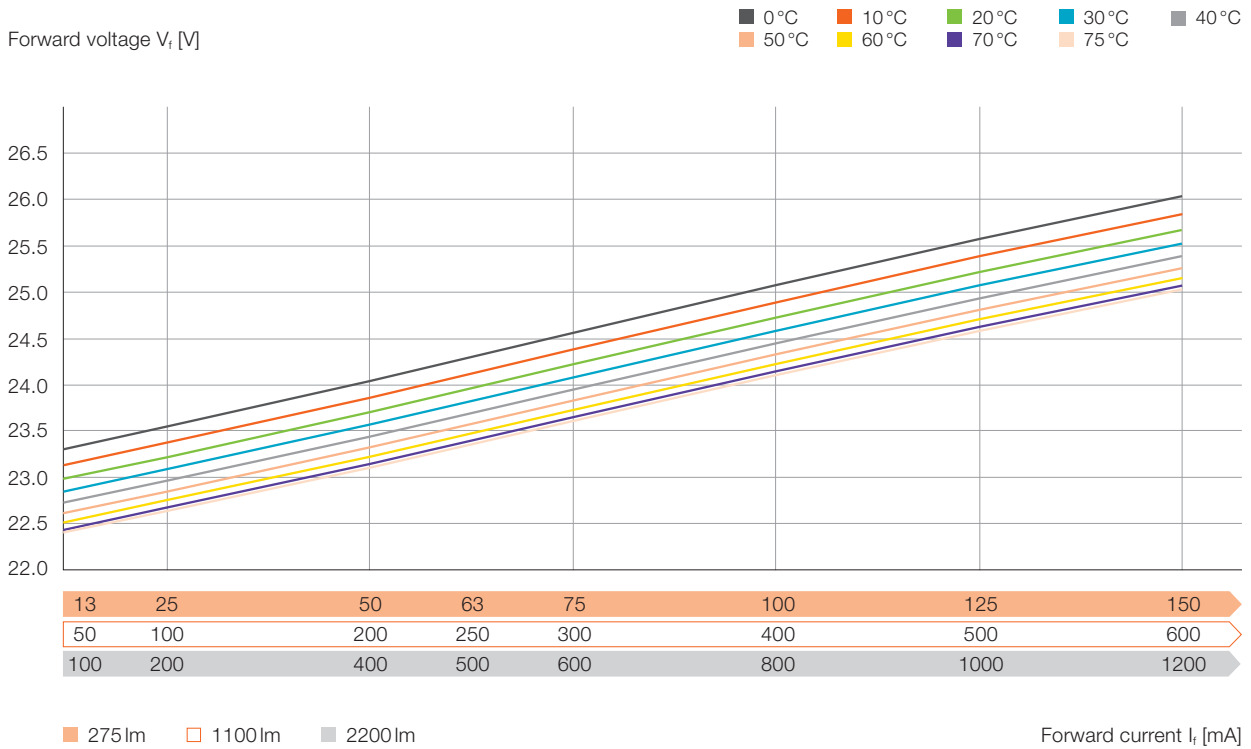

**PL-LIN-Z6, 2000lm, 4000lm, CRI > 90**

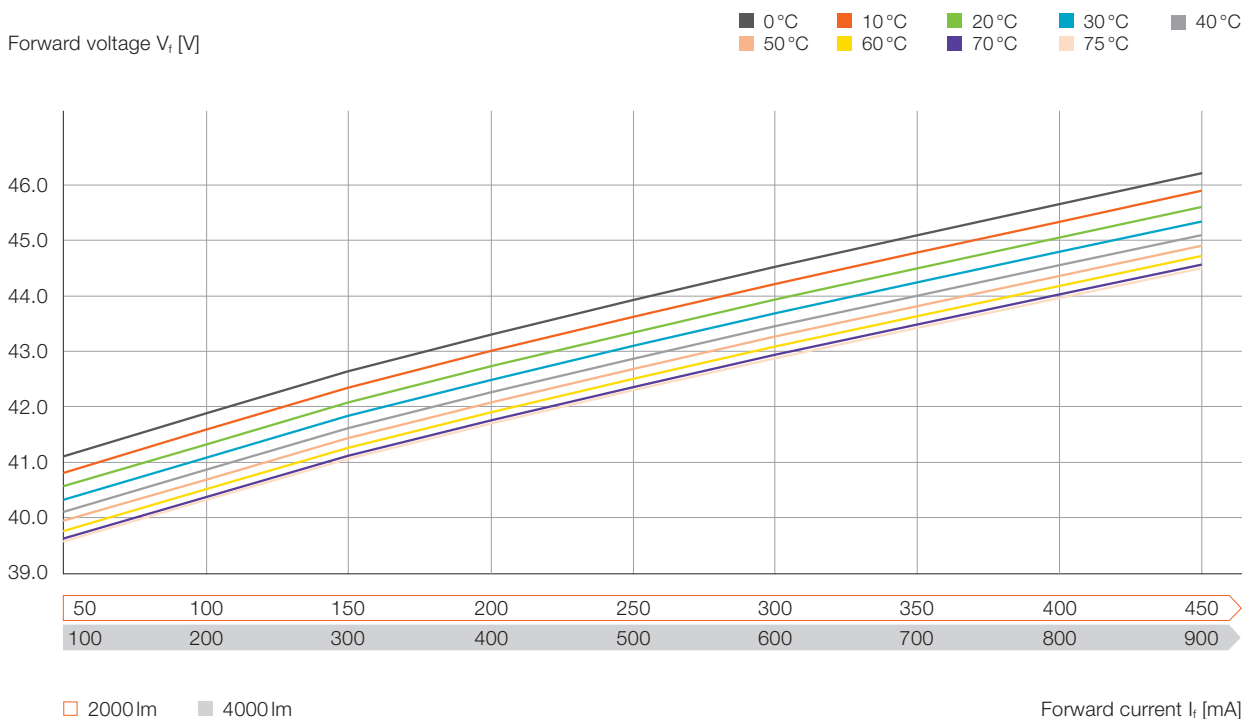

**PL-LIN-Z6, 2200lm, CRI > 90**

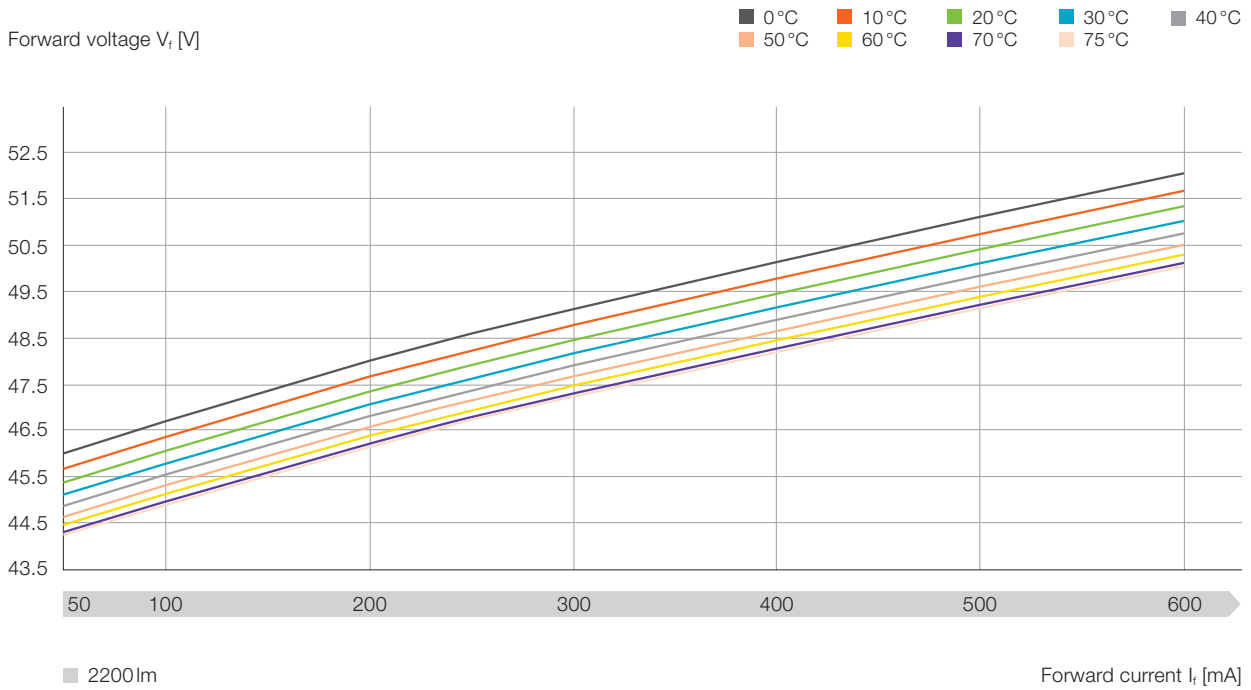

**PL-LIN-Z6, 4000lm, CRI > 90**

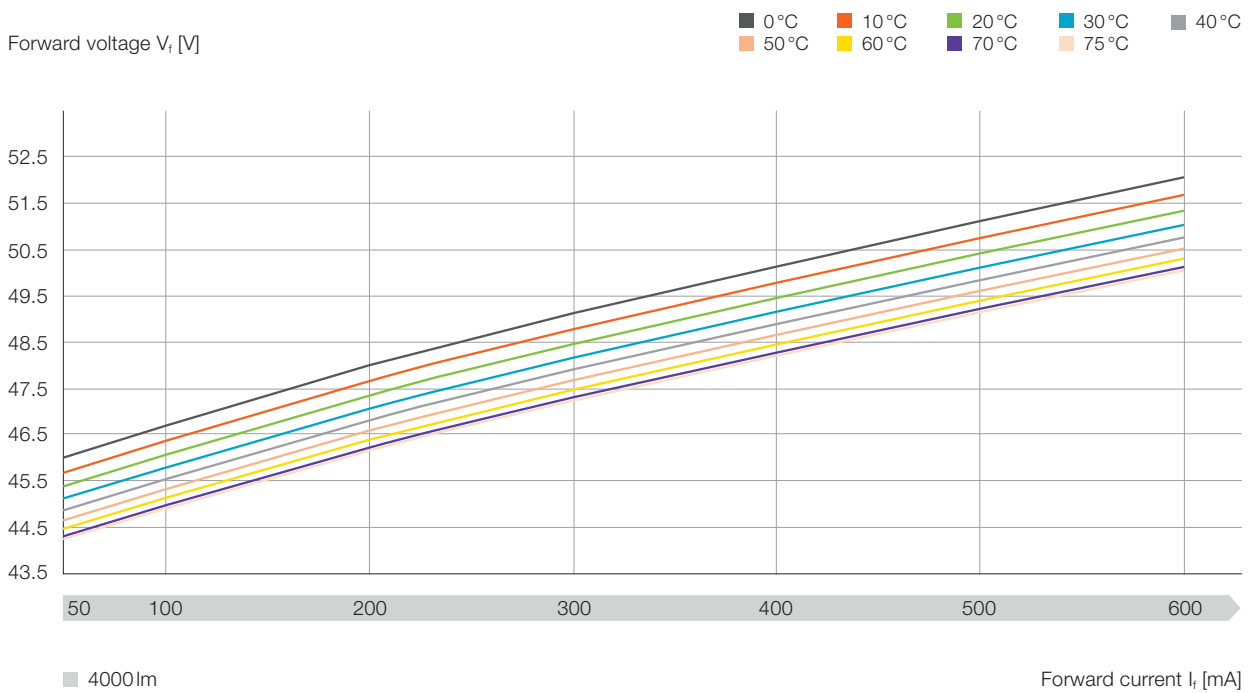

**PL-LIN-Z5, 1100lm, 2200lm, CRI > 80**

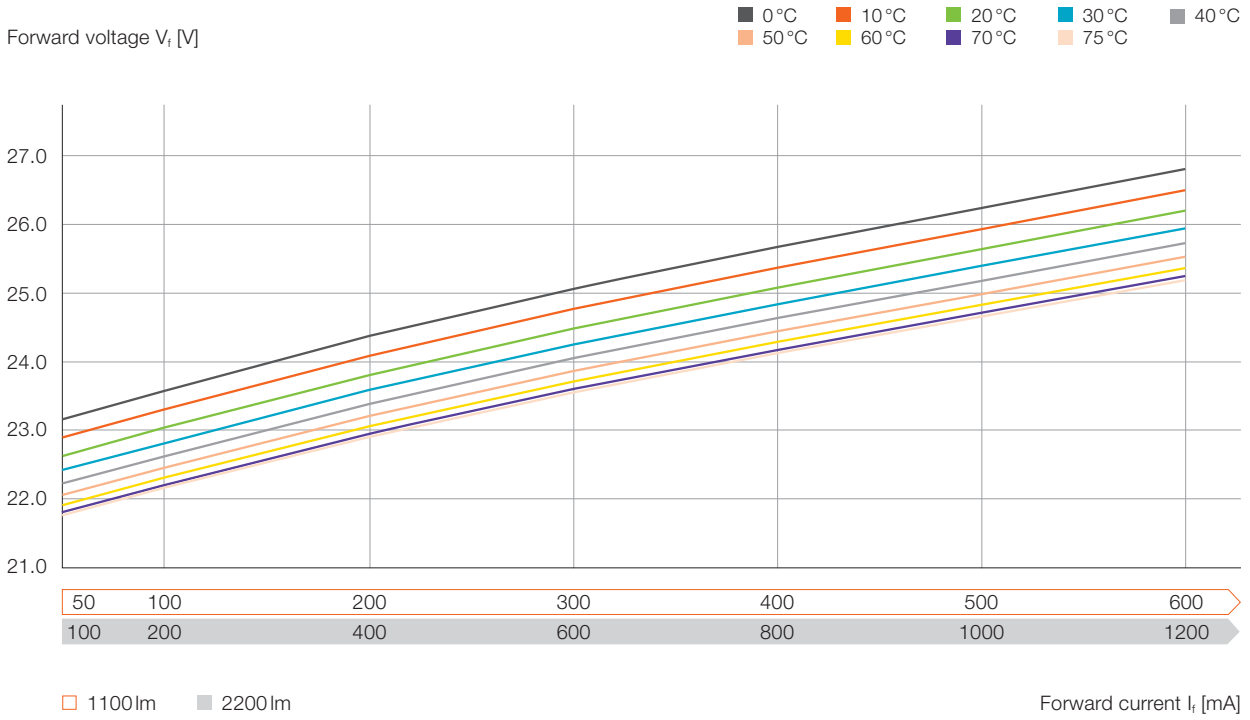

**PL-LIN-Z5, 2000lm, 4000lm, CRI > 80**

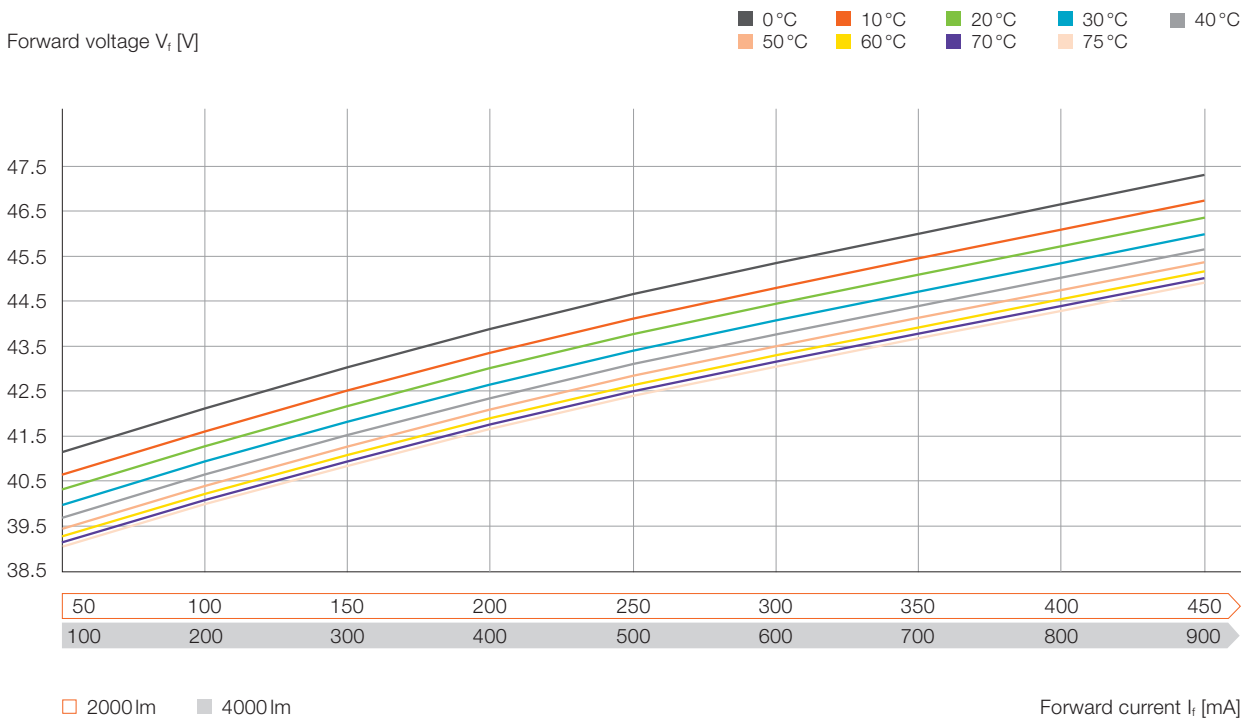

**PL-LIN-Z5, 2200lm, CRI > 80**

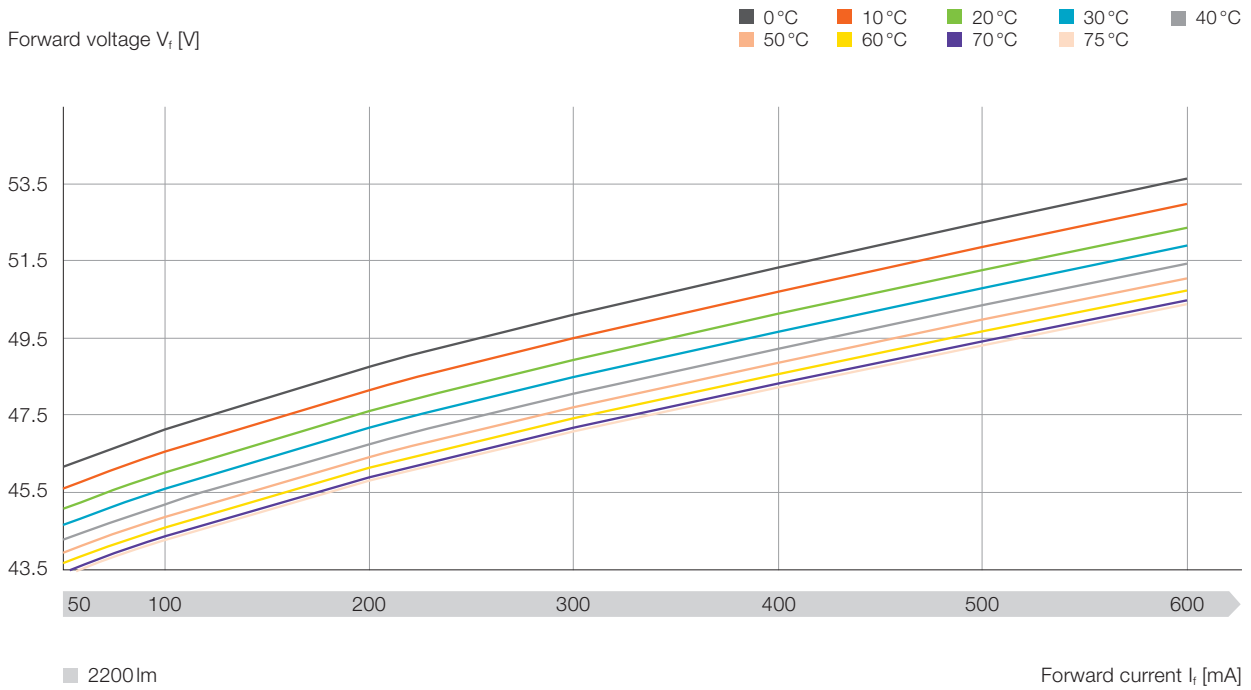

**PL-LIN-Z5, 4000lm, CRI > 80**

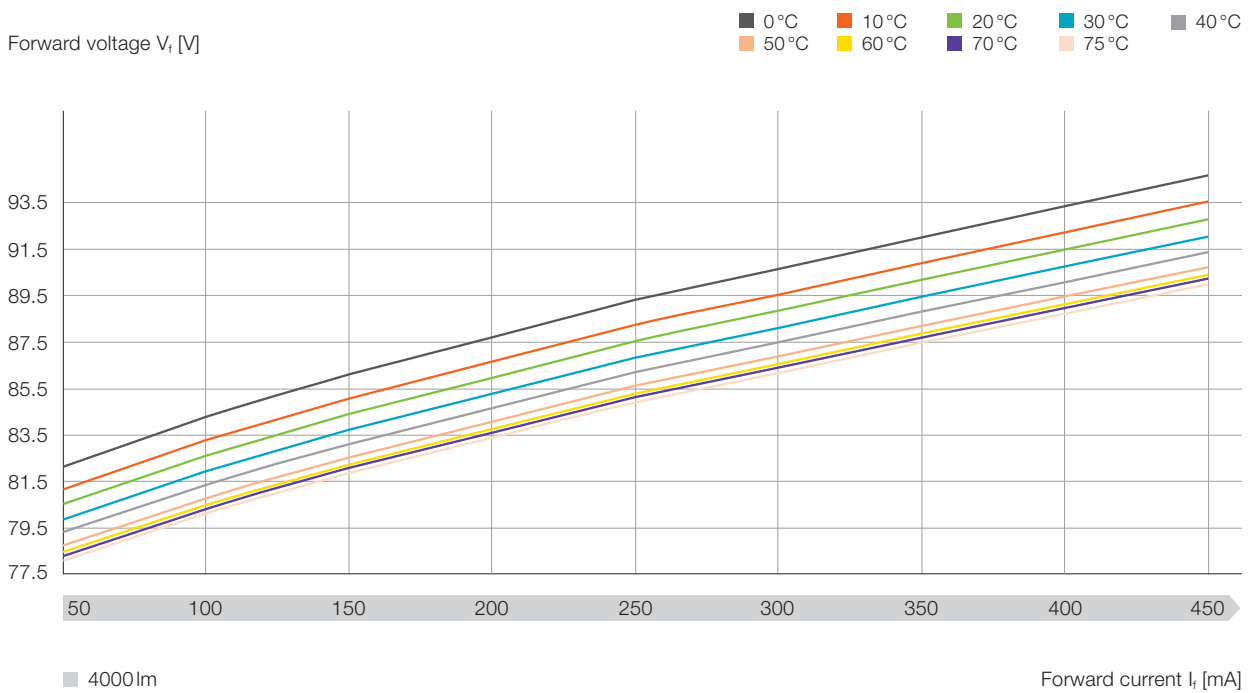

**PL-LIN-Z5, 4400lm, CRI > 80**

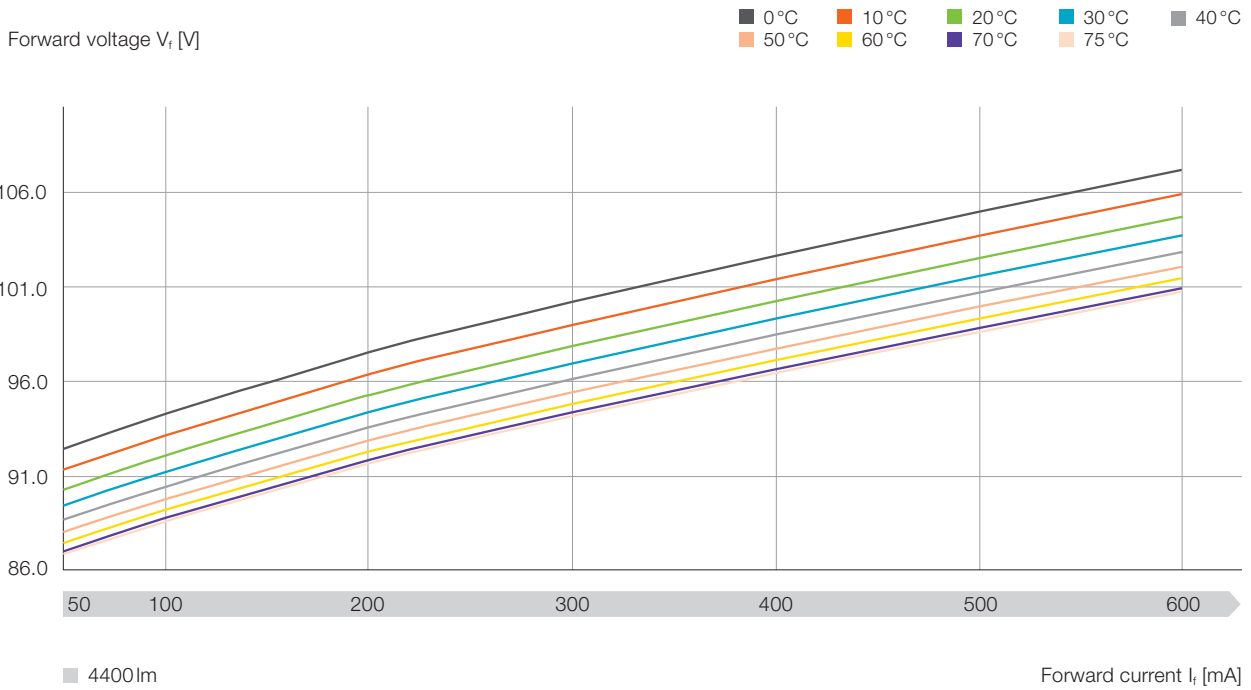

**PL-LIN-Z5, 5500lm, CRI > 80**

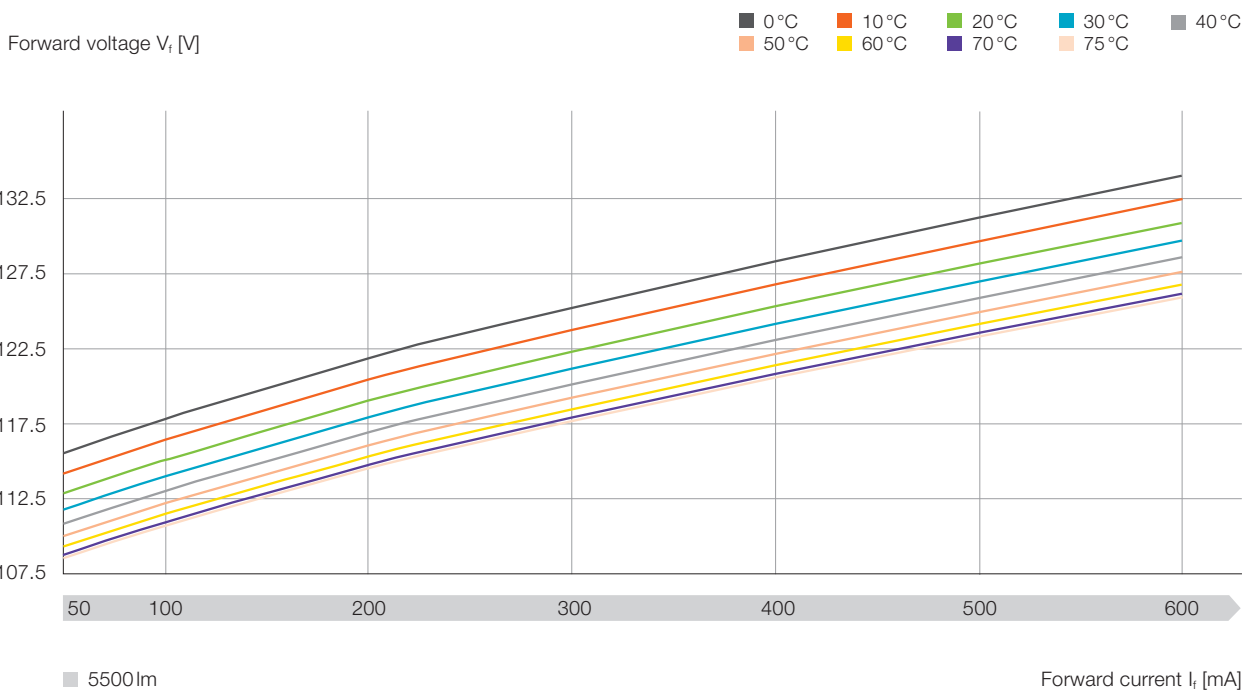

# 4 LED systems: PrevaLED® Linear G5/G6 and OPTOTRONIC® LED drivers

## 4.1 LED module/driver combinations

PrevaLED® Linear G5/G6 LED modules are designed to be used together with Inventronics OPTOTRONIC® LED drivers – both in the SELV ( $V_i < 54\text{V}$ ) and non-SELV ( $V_i > 54\text{V}$ ) range. The new PrevaLED® Linear family includes three types of modules, the LV type, the HV type and the LV/HV type. The LV type is designed for an easy connection in parallel even for modules of different lengths. The HV type is designed for an easy connection in series even for modules of different lengths. The LV/HV type can be combined either with the LV type or with the HV type.

### Series and parallel connection

PrevaLED® Linear G5/G6 LED modules can be connected either in parallel or in series, as shown in the pictures below. In order to mix modules with a different length, they have to be of the same type (LV or HV). And they also need to have the same luminous flux per length (e.g. PL-LIN-Z6 1100-827 280X20-LV/HV + PL-LIN-Z6 2200-827 560X20-LV). If only one specific module is used, it can be connected in parallel as well as in series.

All PrevaLED® Linear G5/G6 LED modules are designed for a maximum voltage of 250 V, which must not be exceeded when the modules are connected in series.

### PrevaLED® Linear G5/G6 LV LED modules connected in parallel to an LED driver

If LV LED modules are connected in parallel, the “+” of one LED module is connected to the “+” of the following LED module and the “-” of one LED module is connected to the “-” of the following LED module. The last LED module in the chain is connected to the LED driver (here again, the “+” of the LED module is connected with the “+” of the LED driver and the “-” of the LED module with the “-” of the LED driver).

A schematic of four LED modules connected in parallel to an LED driver is shown below, together with a picture of two modules connected in parallel.

### PrevaLED® Linear G5/G6 LV LED modules connected in parallel to an OPTOTRONIC® LED driver



### Example: Parallel connection of two PrevaLED® Linear G5/G6 LV LED modules



### PrevaLED® Linear G5/G6 HV LED modules connected in series to an LED driver

HV LED modules can easily be connected in series to LED drivers. A schematic of two modules connected in series is shown below.

### PrevaLED® Linear G5/G6 HV LED modules connected in series to an OPTOTRONIC® LED driver



**Example: Series connection of two PrevaLED® Linear G5/G6 HV LED modules**

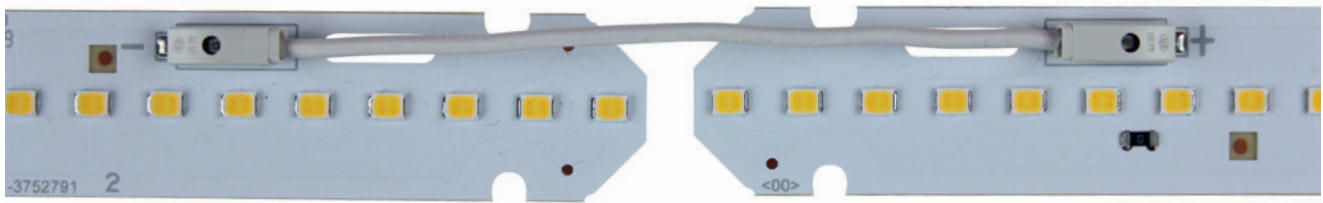

Electrically, parallel and/or series connections of PrevaLED® Linear G5/G6 LED modules have the following impacts on the electrical parameters:

**When connecting two modules in parallel:**

$$V_f \text{ (two modules)} = V_f \text{ (single module)}$$

$$I_f \text{ (two modules)} = 2 \times I_f \text{ (single module)}$$

**When connecting two modules in series:**

$$V_f \text{ (two modules)} = 2 \times V_f \text{ (single module)}$$

$$I_f \text{ (two modules)} = I_f \text{ (single module)}$$

**When connecting N modules in parallel:**

$$V_f \text{ (N modules)} = V_f \text{ (single module)}$$

$$I_f \text{ (N modules)} = N \times I_f \text{ (single module)}$$

**When connecting N modules in series:**

$$V_f \text{ (N modules)} = N \times V_f \text{ (single module)}$$

$$I_f \text{ (N modules)} = I_f \text{ (single module)}$$

If LED modules with different lengths are mixed and connected in parallel, the currents need to be added up. In series connection, however, the voltages need to be added up. The calculation can be simplified by assuming the complete length is done with the smallest LED module used, e.g. PL-LIN-Z6 1100-827 280X20-LV/HV + PL-LIN-Z6 2200-827 560X20-LV leads to the same result as calculating 3 x PL-LIN-Z6 1100-827 280X20-LV/HV.

**Definition of the XsYp notation:**

The tables in the datasheets and in section 4.3 (see [here](#)) use the “XsYp” notation with “X” representing the number of LED modules that are connected in series and “Y” representing the number of LED modules connected in parallel.

## XsYp notation

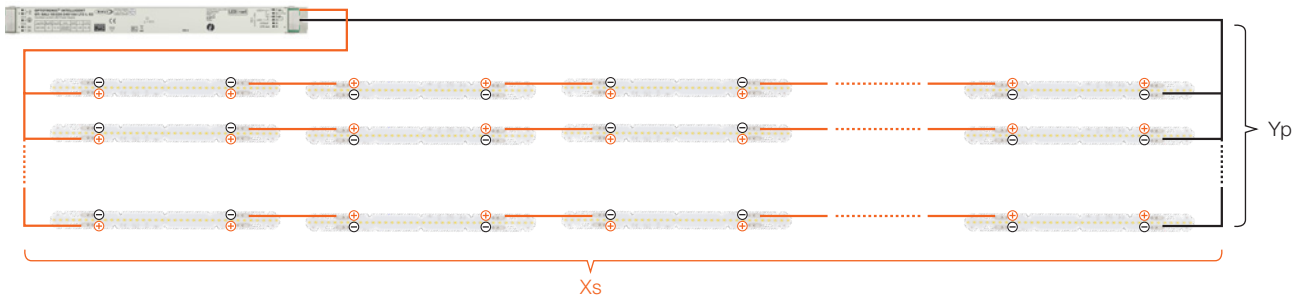

The tables in the datasheets do not only provide information about how many LED modules can be connected to an OPTOTRONIC® constant-current LED driver, but they also show the possible wiring schematics.

### 4.2 Installation examples

Connection scenarios of the PrevaLED® Linear G5/G6 LED modules as shown below are based on the most common applications. Many other scenarios, e.g. three LED modules (1s3p or 3s1p) are possible. If you have any further questions about the installation of PrevaLED® Linear G5/G6 LED modules, please consult your local Inventronics sales representative.

#### Please note:

The following calculations were done using nominal conditions (if not mentioned otherwise) for forward current ( $I_f$ ), luminous flux, etc. These settings can, of course, be adjusted. This can change the LED module/LED driver combinations listed in the examples.

#### Example 1: 1s5p – Five LED modules connected in parallel to an OPTOTRONIC® SELV LED driver

Application example: 5-ft damp-proof luminaire  
 Example components: PrevaLED® Linear G5/G6:  
 PL-LIN-Z6 1100-840 280X20-LV/HV, five modules

#### Five LED modules connected in parallel to an OPTOTRONIC® SELV LED driver



Electrical parameters of one G5/G6:  
 PL-LIN-Z6 1100-840 280X20-LV/HV :  
 Forward current ( $I_f$ ) = 250 mA, forward voltage ( $V_f$ ) = 23.6 V  
 Five LED modules connected in parallel:  
 Forward voltage:  
 $V_f$  (five modules) =  $V_f$  (one module) = 23.6 V  
 Forward current:  
 $I_f$  (five modules) = 5 x  $I_f$  (one module) = 1250 mA

#### Please note:

If the LED modules are connected in parallel to the LED driver, it is possible to combine 280-mm LED modules and 560-mm LED modules with the same LED pitch (i.e. 275-lm LED modules with 550-lm LED modules and 1100-lm LED modules with 2200-lm LED modules). The main benefit is that less components have to be connected and assembled. (There can also be a price advantage.) The electrical parameters remain unchanged.

From the Inventronics LED driver portfolio, there are some drivers that would fit, e.g.:

- OT FIT 75/220-240/1400 CS L G2  
 (as a linear on/off driver)
- OTi DALI 50/220-240/1A4 LT2 L G2  
 (as a linear dimmable DALI driver)

**For our example, this means:**

Electrical parameters of:

one PL-LIN-Z6 1100-840 280X20-LV/HV:

$I_f = 250 \text{ mA}$ ,  $U_f = 23.6 \text{ V}$ ,

one PL-LIN-Z6 2200-840 560X20-LV:

$I_f = 500 \text{ mA}$ ,  $U_f = 23.6 \text{ V}$



Parallel connection of 2 x PL-LIN-Z6 2200-840 560X20-LV

+ 1 x PL-LIN-Z6 1100-840 280X20-LV/HV

$U_f$  (2 x PL-LIN-Z6 2200-840 560X20-LV + 1 x PL-LIN-Z6 1100-840 280X20-LV/HV) =

$U_f$  (one module) = 23.6V

(same as before)

$I_f$  (2 x PL-LIN-Z6 2200-840 560X20-LV + 1 x PL-LIN-Z6 1100-840 280X20-LV/HV)

= 2 x  $I_f$  (PL-LIN-Z6 2200-840 560X20-LV) + 1 x  $I_f$  (PL-LIN-Z6 1100-840 280X20-LV/HV) =

2 x 500 mA + 1 x 250 mA = 1250 mA

(same as before)

**Example 2: 4s1p – Four LED modules connected in series to an OPTOTRONIC® non-SELV LED driver**

Application example: 4-ft damp-proof luminaire

Example components: PrevaLED® Linear G5/G6:

PL-LIN-Z6 1100-840 280X20-LV/HV, four modules

**Four LED modules connected in series to an OPTOTRONIC® non-SELV LED driver**



Electrical parameters of one PL-LIN-Z6 1100-840 280X20-LV/HV :

$I_f = 250 \text{ mA}$ ,  $U_f = 23.6 \text{ V}$

Four LED modules connected in series:

$U_f$  (four modules) = 4 x  $U_f$  (one module) = 94.4 V

$I_f$  (four modules) =  $I_f$  (one module) = 250 mA

From the Inventronics LED driver portfolio, there are some drivers that would fit, e.g.:

- OT FIT 35/220-240/350 D NFC L  
(as a linear on/off driver)
- OTi DALI 35/220-240/400 D NFC F L G4  
(as a linear dimmable DALI driver)

**Example 3: 3s2p – Two strings of three LED modules, each connected in parallel to an OPTOTRONIC® non-SELV LED driver**

**Two strings of three LED modules, each connected in parallel to an OPTOTRONIC® non-SELV LED driver**

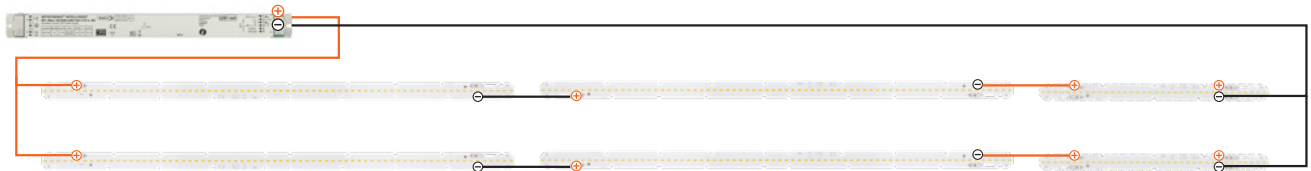

**For our example, this means:**

Electrical parameters of:  
 one PL-LIN-Z6 1100-840 280X20-LV/HV:  
 $I_f = 250 \text{ mA}$ ,  $U_f = 23.6 \text{ V}$ ,  
 one PL-LIN-Z6 2200-840 560X20-HV:  
 $I_f = 250 \text{ mA}$ ,  $U_f = 47.1 \text{ V}$



**Two 2-ft and one 1-ft module/s connected in series:**

$U_f$  (two 2-ft modules) =  $2 \times U_f$  (two 2-ft HV modules) =  $94.2 \text{ V}$  +  $1 \times U_f$  (one LV/HV module) =  $23.6 \text{ V}$  = total  $117.8 \text{ V}$   
 $I_f$  (three modules) =  $I_f$  (one module) =  $250 \text{ mA}$

**Two 2-ft and one 1-ft module/s connected in series, connected two times in parallel:**

$U_f$  (six modules) =  $1 \times U_f$  (three modules) =  $117.8 \text{ V}$   
 $I_f$  (six modules) =  $2 \times I_f$  (three modules) =  $500 \text{ mA}$

There are some drivers that would fit, e.g.:

- OT FIT 75/220-240/550 D NFC F L  
 (as a linear on/off driver)
- OTI DALI 75/220-240/550 D LT2 NFC IND L  
 (as a linear dimmable DALI driver)

**Example 4: 2s4p – Four strings of two LED modules, each connected in parallel to an OPTOTRONIC® SELV LED driver**

Application example: 2" x 2" troffer luminaire  
 Example components: PrevaLED® Linear G5/G6:  
 PL-LIN-Z6 1100-840 280X20-LV/HV, eight modules

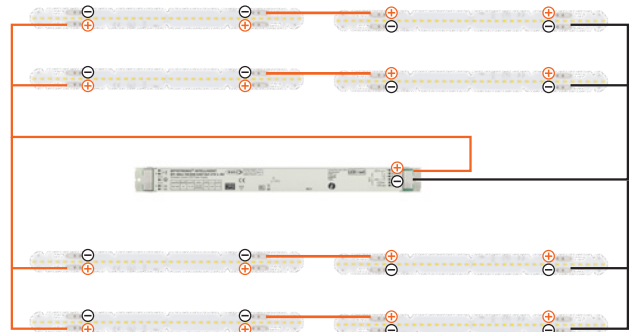
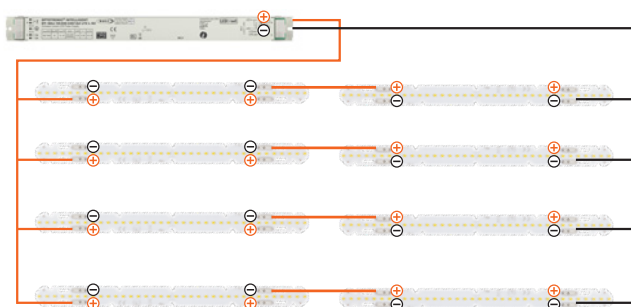

### 4.3 System combination tables

In different applications, PrevaLED® Linear G5/G6 LED modules can be used in a wide range of LED module/ driver combinations. The most important (but not all possible) combinations are shown in the tables below.

#### How to read the matching list

2-6	First line: Possible amount of modules
2-4s1-3p	Second line: Possibilities of connections

**Example:**

2-6	means from 2 up to 6 modules possible
1-4s1-3p	means 1s2p, 1s3p, 2s1p, 2s2p, 2s3p, 3s1p, 3s,2p, 4s1p are the possible configurations

#### OTi DALI (wide-window driver – SELV) Dimmable\*

				DALI SELV				DEXAL SELV	
	V	mA	W	OTI DALI35/220-240/700 LT2L G2	OTI DALI50/220-240/1A4 LT2L G2	OTI DALI 80/220-240/1A6 LT2 L	OTI DALI 80/220-240/2A1 LT2 L	OTI 30/120-277/1A0 DX L	OTI 50/120-277/1A4 DX L
1100-8xx 280x20-LV/HV	23.5	250	5.9	1-4 1-2s1-2p	4-8 1-2s3-5p	3-12 1-2s3-6p	6-12 1-2s4-8p	2-4 1-2s1-4p	3-8 1-2s3-5p
2000-8xx 280x20-LV/HV	43.1	275	11.8	1-2 1s1-2p	3-4 1s3-4p	3-5 1s3-5p	4-6 1s4-6p	1-2 1s1-2p	3-4 1s3-4p
2200-8xx 560x20-LV	23.5	500	11.8	1-2 1-2s1p	2-4 1-2s2p	2-6 1-2s2-3p	3-6 1-2s2-4p	1-2 1-2s1-2p	2-4 1-2s2p
4000-8xx 560x20-LV	43.1	550	23.7	1	2 1s2p	2 1s2p	2-3 1s2-3p	1	2 1s2p
4FT SELV (2x2200lm)	23.5	1000	23.6		1-2 1-2s1p	1-2 1-2s1p	2 1-2s1-2p	1	1-2 1-2s1p
4FT SELV (2x4000lm)	43.1	1100	47.2		1	1	1		1
5FT SELV (2x2200lm + 1x1100lm)	23.5	1250	29.5		1	1-2 1-2s1p	2 2s1p		1
5FT SELV (2x4000lm + 1x2000lm)	43.1	1350	53.3			1	1		

\* These combinations are valid if the modules are driven with nominal current. If other currents are used, other combinations are possible.

**OT FIT CS (triple-current driver – SELV) Non-dimmable\***

	V	mA	W	On/off			On/off NFC		
				OT FIT 35/220-240/700 CS L G2	OT FIT 55/220-240/1A0 CS L G2	OT FIT 75/220-240/1A4 CS L G2	OT FIT 35 NFC L	OT FIT 55 NFC L	OT FIT 75 NFC L
				27-54 V	27-54 V	27-54 V	20-54 V	20-54 V	20-54 V
1100-8xx 280x20-LV/HV	23.5	250	5.9	4 2s2p	8 2s4p	10 2s5p	4 2s2p	6-8 2s3-4p	5-10 1-2s3-5p
2000-8xx 280x20-LV/HV	43.1	275	11.8	2 1s2p	3 1s3p	4-5 1s4-5p	2 1s2p	3 1s3p	3-5 1s3-5p
2200-8xx 560x20-LV	23.5	500	11.8	2 2s1p	4 2s2p	4 2s2p	2 2s1p	4 2s2p	4 2s2p
4000-8xx 560x20-LV	43.1	550	23.7	1	1	2 1s2p	1		2 1s2p
4FT SELV (2x2200lm)	23.5	1000	23.6		2 2s1p			2 2s1p	2 2s1p
4FT SELV (2x4000lm)	43.1	1100	47.2			1			1
5FT SELV (2x2200lm + 1x1100lm)	23.5	1250	29.5			2 2s1p			1-2 1-2s1p
5FT SELV (2x4000lm + 1x2000lm)	43.1	1350	53.3			1			1

\* These combinations are valid if the modules are driven with nominal current. If other currents are used, other combinations are possible.

**OTi (wide-window driver – Non-isolated)\***

	V	mA	W	Ultraflat		LEDset			
				OTi DALI 35/220-240/400D LT2UFL	OTi DALI 75/220-240/700D LT2UFL	OTi DALI 35/220-240/400D LT2L	OTi DALI 60/220-240/550D LT2L	OTi DALI 90/220-240/700D LT2L	OTi DALI 90/220-240/1A0 LT2L
1100-8xx 280x20-LV/HV	23.5	250	5.9	3-6 3-6s1p	3-12 3-10s1-2p	3-6 3-6s1p	3-10 3-10s1-2p	3-14 3-10s1-2p	3-14 3-10s1-4p
2000-8xx 280x20-LV/HV	42.1	275	11.8	2-3 2-3s1p	2-6 2-5s1-2p	2-3 2-3s1p	2-5 2-5s1-2p	2-6 2-5s1-2p	2-6 2-5s1-3p
2200-8xx 560x20-HV	47.1	250	11.8	1-3 2-3s1p	2-6 2-5s1-2p	2-3 2-3s1p	2-5 2-5s1-2p	2-6 2-5s1-2p	2-6 2-5s1-4p
4000-8xx 560x20-HV	86.2	275	23.7	1	1-2 1-2s1-2p	1	1-2 1-2s1-2p	1-2 1-2s1-2p	1-3 1-2s1-3p
4FT non-SELV (2x2200lm)	94.2	250	23.6	1	1-2 1-2s1-2p	1	1-2 1-2s1-2p	1-2 1-2s1-2p	1-3 1-2s1-3p
4FT non-SELV (2x4000lm)	172.4	275	47.4		1		1	1	1
5FT non-SELV (2x2200lm + 1x1100lm)	117.7	250	29.5	1	1-2 1-2s1-2p	1	1-2 1-2s1-2p	1-2 1-2s1-2p	1-3 1-2s1-3p
5FT non-SELV (2x4000lm + 1x2000lm)	214.5	275	59.2		1		1	1	1

\* These combinations are valid if the modules are driven with nominal current. If other currents are used, other combinations are possible.

**Operation with OPTOTRONIC® non-SELV/non-isolated LED drivers**

**LEDset and single-current driver (Non-isolated)\***

	LEDset				Single current		
	OT FIT 25/220-240/300 D LT2 L	OT FIT 35/220-240/350D LT2 L	OT FIT 75/220-240/550 D LT 2 L	OT FIT 50/220-240/350 D L	OT FIT 50/220-240/250 D L	OT FIT 50/220-240/300 D L	OT FIT 50/220-240/350 D L
1100-8xx 280x20-LV/HV	2-4 2-4s1p	3-5 3-5s1p	3-12 3-9s1-2p	3-18 3-9s1-3p	3-9 3-9s1p	3-7 3-7s1p	3-6 3-6s1p
2000-8xx 280x20-LV/HV	1-2 1-2s1p	2 2s1p	2-6 2-5s1-2p	2-10 2-5s1-2p	2-5 2-5s1p	2-4 2-4s1p	2-3 2-3s1p
2200-8xx 560x20-HV	1-2 1-2s1p	2 2s1p	2-6 2-4s1-2p	2-8 2-4s1-3p	2-4 2-s1p	2-3 2-3s1p	2-3 2-3s1p
4000-8xx 560x20-HV	1	1	1-2 1-2s1-2p	1-4 1-2s1-2p	1-2 1-2s1p	1-2 1-2s1p	1
4FT non-SELV (2 x 2200 lm)	1	1	1-2 1-2s1-2p	1-4 1-2s1-3p	1-2 1-2s1p	1	1
4FT non-SELV (2 x 4000 lm)			1	1-2 1s1-2p	1	1	
5FT non-SELV (2 x 2200 lm + 1 x 1100 lm)		1	1-2 1-1s1-2p	1-4 1s1-3p	1	1	1
5FT non-SELV (2 x 4000 lm + 1 x 2000 lm)			1	1-2 1s1-2p			

\* These combinations are valid if the modules are driven with nominal current. If other currents are used, other combinations are possible.

**OTI DALI (wide-window driver – SELV) Dimmable\***

				DALI SELV				DEXAL SELV	
	V	mA	W	OTI DALI 95/220-240/700 LT2L G2	OTI DALI 50/220-240/1A4 LT2L G2	OTI DALI 80/220-240/1A6 LT2 L	OTI DALI 80/220-240/2A1 LT2 L	OTI 30/120-277/1A0 DX L	OTI 50/120-277/1A4 DX L
1100-9xx 280x20-LV/HV	23.8	300	7.2	1-4 1-2s1-2p	3-6 1-2s2-4p	2-10 1-2s2-5p	5-11 1-2s4-7p	2-4 1-2s1-3p	3-6 1-2s2-4p
2000-9xx 280x20-LV/HV	43.2	300	13.0	1-2 1s1-2p	2-4 1s2-4p	1-5 1s2-5p	4-6 1s4p	1-2 1s1-2p	2-3 1s2-3p
2200-9xx 560x20-LV	23.8	600	14.3	1-2 1-2s1p	2 1-2s1-2p	1-4 1-2s1-2p	3-4 1-2s2-3p	1-2 1-2s1p	2-2 1-2s1-2p
4000-9xx 560x20-LV	43.2	600	26.0	1	1-2 1s1-2p	1-2 1s1-2p	2-3 1s2-3p	1	1
4FT SELV (2x2200lm)	23.8	600	28.6		1	1-2 1-2s1p	2 1-2s1p		1
4FT SELV (2x4000lm)	43.2	1200	62.0		1	1	1		
5FT SELV (2x2200lm + 1 x 1100lm)	23.8	900	35.8			1-2 1-2s1p	1-2 1-2s1p		
5FT SELV (2x4000lm + 1 x 2000lm)	43.2	1500	75.0			1	1		

\* These combinations are valid if the modules are driven with nominal current. If other currents are used, other combinations are possible.

**OT FIT CS (triple-current driver – SELV) Non-dimmable\***

				On/off			On/off NFC		
	V	mA	W	OT FIT 35/220-240/700 CS L G2	OT FIT 55/220-240/1A0 CS L G2	OT FIT 75/220-240/1A4 CS L G2	OT FIT 35 NFC L	OT FIT 55 NFC L	OT FIT 75 NFC L
				27-54 V	27-54 V	27-54 V	20-54 V	20-54 V	20-54 V
1100-9xx 280x20-LV/HV	23.8	300	7.2	4 2s2p	6 2s3p	8 2s4p	2-4 1-2s1-2p	6 2s3p	4-8 1-2s2-4p
2000-9xx 280x20-LV/HV	43.2	300	13.0	2 1s2p	3 1s3p	4 1s4p	1-2 1s1-2p	3 1s3p	3-4 1s3-4p
2200-9xx 560x20-LV	23.8	600	14.3	2 2s1p		2 2s2p	1-2 1-2s1p		2-4 1-2s1-2p
4000-9xx 560x20-LV	43.2	600	26.0	1		2 1s2p	1		2 1s2p
4FT SELV (2x2200lm)	23.8	600	28.6			2 2s1p			1-2 1-2s1p
4FT SELV (2x4000lm)	43.2	1200	62.0			1			1
5FT SELV (2x2200lm + 1x1100lm)	23.8	900	35.8						
5FT SELV (2x4000lm + 1x2000lm)	43.2	1500	75.0						

\* These combinations are valid if the modules are driven with nominal current. If other currents are used, other combinations are possible.

**OTi (wide-window driver – Non-isolated)\***

				Ultraflat		LEDset			
	V	mA	W	OTi DALI 35/220-240/400D LT2UFL	OTi DALI 75/220-240/700D LT2UFL	OTi DALI 35/220-240/400D LT2L	OTi DALI 60/220-240/550D LT2L	OTi DALI 90/220-240/700D LT2L	OTi DALI 90/220-240/1A0 LT2L
1100-9xx 280x20-LV/HV	23.8	300	7.2	3-5 3-5s1p	3-10 3-10s1-2p	31-5 3-5s1p	3-8 3-8s1p	3-12 3-10s1-2p	3-12 3-10s1-3p
2000-9xx 280x20-LV/HV	43.2	300	13.0	2 2s1p	2-5 2-5s1-2p	2 2s1p	2-4 2-4s1p	2-6 2-5s1-2p	2-6 2-5s1-3p
2200-9xx 560x20-HV	47.7	300	14.3	2 2s1p	2-5 2-5s1-2p	2 2s1p	2-4 2-4s1p	2-6 2-5s1-2p	2-6 2-5s1-3p
4000-9xx 560x20-HV	86.5	300	26.0	1	1-2 1-2s1-2p	1	1-2 1-2s1p	1-2 1-2s1-2p	1-3 1-2s1-3p
4FT non-SELV (2x2200lm)	86.4	300	28.6	1	1-2 1-2s1-2p	1	1-2 1-2s1p	1-2 1-2s1-2p	1-3 1-2s1-3p
4FT non-SELV (2x4000lm)	173.0	300	52.0		1		1	1	1
5FT non-SELV (2x2200lm + 1x1100lm)	110.2	300	35.8	1	1-2 1-2s1-2p	1	1	1-2 1-2s1-2p	1-2 1-2s1-2p
5FT non-SELV (2x4000lm + 1x2000lm)	216.2	300	65.0		1			1	1

\* These combinations are valid if the modules are driven with nominal current. If other currents are used, other combinations are possible.

**LEDset and single-current driver (Non-isolated)\***

	LEDset				Single current		
	OT FIT 25/220- 240/300 D LT2 L	OT FIT 35/220- 240/350D LT2 L	OT FIT 75/220- 240/550 D LT 2 L	OT FIT 120/220- 240/750 D LT 2	OT FIT 50/220- 240/250 D L	OT FIT 50/220- 240/300 D L	OT FIT 50/220- 240/350 D L
1100-9xx 280x20-LV/HV	2-3 2-3s-1p	3-4 3-4s1p	3-9 3-9s1p	3-16 3-9s1-2p	3-8 3-8s1p	3-7 3-7p1s	3-6 3-6s1p
2000-9xx 280x20-LV/HV	1	2 2s1p	2-5 2-5s1p	2-8 2-5s1-2p	2-4 2-4s1p	2-3 2-3s1p	2-3 2-3s1p
2200-9xx 560x20-HV	1	2 2s1p	2-4 2-4s-1p	2-8 2-4s1-2p	2-4 2-4s1p	2-3 2-3s1p	2-3 2-3s1p
4000-9xx 560x20-HV		1	1-2 1-2s1p	1-4 1-2s1-2p	1-2 1-2s1p	1	1
4FT non-SELV (2 x 2200lm)		1	1-2 1-2s1p	1-4 1-2s1-2p	1-2 1-2s1p	1	1
4FT non-SELV (2 x 4000lm)			1	1-2 1s1-2p	1		
5FT non-SELV (2 x 2200lm + 1 x 1100lm)			1	1-2 1s1-2p	1	1	1
5FT non-SELV (2 x 4000lm + 1 x 2000lm)		1	1-2 1-2s1p	1-4 1-2s1-2p			

\* These combinations are valid if the modules are driven with nominal current. If other currents are used, other combinations are possible.

**OTi DALI (wide-window driver – SELV) Dimmable\***

				DALI SELV				DEXAL SELV	
	V	mA	W	OTI DALI 95/220-240/700 LT2L G2	OTI DALI 50/220-240/1A4 LT2L G2	OTI DALI 80/220-240/1A6 LT2 L	OTI DALI 80/220-240/2A1 LT2 L	OTI 30/120-277/1A0 DX L	OTI 50/120-277/1A4 DX L
1100-8xx 280x20-LV/HV	23.6	250	5.9	1-4 1-2s1-2p	4-8 1-2s2-5p	3-12 1-2s3-6p	6-12 1-2s4-8p	2-4 1-2s1-4p	3-8 1-2s3-5p
2000-8xx 280x20-LV/HV	42.7	250	10.7	1-2 1s1-2p	2-5 1s3-5p	2-6 1-1s3-6p	4-7 1s4-8p	1-2 1s1-2p	3-4 1s3-4p
2200-8xx 560x20-LV	23.6	500	11.8	1-2 1-2s1p	2-4 1-2s2p	2-6 1-2s2-3p	3-6 1-2s2-4p	1-2 1-2s1-2p	2-4 1-2s2p
4000-8xx 560x20-LV	42.7	500	21.3	1	2	1-3 1s2-3p	2-3 1s2-3p	1	2 1s2p
FT SELV (2 x 2200 lm)	23.6	1000	23.6		1-2 1-2s1p	1-2 1-2s1p	2 1-2s1-2p	1	1-2 1-2s1p
4FT SELV (2 x 4000 lm)	42.7	1000	42.7		1	1	1		1
5FT SELV (2 x 2200 lm + 1 x 1100 lm)	23.6	1250	29.5		1	1-2 1-2s1p	2 2s1p		1
5FT SELV (2 x 4000 lm + 1 x 2000 lm)	42.7	1250	53.3		1	1	1		

\* These combinations are valid if the modules are driven with nominal current. If other currents are used, other combinations are possible.

**Non-dimmable\***

				On/off				On / Off NFC	
	V	mA	W	OT FIT 35/220-240/700 CS L G2	OT FIT 55/220-240/1A0 CS L G2	OT FIT 75/220-240/1A4 CS L G2	OT FIT 35 NFC L	OT FIT 55 NFC L	OT FIT 75 NFC L
				27-54V	27-54V	27-54V	20-54V	20-54V	20-54V
1100-8xx 280x20-LV/HV	23.6	250	5.9	4 2s2p	8 2s4p	10 2s5p	4 2s2p	6-8 2s3-4p	5-10 1-2s3-5p
2000-8xx 280x20-LV/HV	42.7	250	10.7	2 1s2p	4 1s4p	5 1s5p	2 1s2p	3-4 1s3-4p	3-5 1s3-5p
2200-8xx 560x20-LV	23.6	500	11.8	2 2s1p	4 2s2p	4 2s2p	2 2s1p	4 2s2p	4 2s2p
4000-8xx 560x20-LV	42.7	500	21.3	1	2 1s2p	2 1s2p	1	2 1s2p	2 1s2p
4FT SELV (2 x 2200 lm)	23.6	1000	23.6			2 2s1p		2 2s1p	2 2s1p
4FT SELV (2 x 4000 lm)	42.7	1000	42.7		1	1		1	1
5FT SELV (2 x 2200 lm + 1 x 1100 lm)	23.6	1250	29.5			2 2s1p			1-2 1-2s1p
5FT SELV (2 x 4000 lm + 1 x 2000 lm)	42.7	1250	53.3			1			1

\* These combinations are valid if the modules are driven with nominal current. If other currents are used, other combinations are possible.

**OTi (wide-window driver – Non-isolated)\***

				Ultraflat		LEDset			
	V	mA	W	OTI DALI 35/220-240/400D LT2UFL	OTI DALI 75/220-240/700D LT2UFL	OTI DALI 35/220-240/400D LT2L	OTI DALI 60/220-240/550D LT2L	OTI DALI 90/220-240/700D LT2L	OTI DALI 90/220-240/1A0 LT2L
1100-8xx 280x20-LV/HV	23.6	250	5.9	3-6 3-6s1p	3-12 3-10s1- 2p	3-6 3-6s1p	3-10 3-10s1- 2p	3-14 3-10s1- 2p	3-14 3-10s1- 4p
2000-8xx 280x20-LV/HV	42.7	250	10.7	2-3 2-3s1p	2-7 2-5s1-2p	2-3 2-5s1p	2-5 2-5s1-2p	2-8 2-5s1-2p	2-8 2-5s1-4p
2200-8xx 560x20-HV	27.1	250	11.8	2-3 2-3s1p	2-6 2-5s1-2p	2-3 2-3s1p	2-5 2-5s1-2p	2-6 2-5s1-2p	2-6 2-5s1-4p
4000-8xx 560x20-HV	85.3	250	21.3	1	1-2 1-2s1-2p	1	1-2 1-2s1-2p	1-4 1-2s1-2p	1-4 1-2s1-4p
4FT non-SELV (2 x 2200 lm)	94.3	250	23.6		1-2 1-2s1-2p		1-2 1-2s1-2p	1-2 1-2s1-2p	1-3 1-2s1-3p
4FT non-SELV (2 x 4000 lm)	170.7	250	42.7		1		1	1-2 1s1- 2p	1-2 1s1- 2p
5FT non-SELV (2 x 2200 lm + 1 x 1100 lm)	117.9	250	29.5	1	1-2 1-2s1-2p	1	1-2 1-2s1-2p	1-2 1-2s1-2p	1-3 1-2s1-3p
5FT non-SELV (2 x 4000 lm + 1 x 2000 lm)	213.4	250	53.3		1		1	1	1

\* These combinations are valid if the modules are driven with nominal current. If other currents are used, other combinations are possible.

**LEDset and single-current driver (Non-isolated)\***

				Ultraflat				LEDset		
	V	mA	W	OT FIT 25/220-240/300 D LT2 L	OT FIT 35/220-240/350D LT2 L	OT FIT 75/220-240/550 D LT 2 L	OT FIT 120/220-240/750 D LT 2	OT FIT 50/220-240/250 D L	OT FIT 50/220-240/300 D L	OT FIT 50/220-240/350 D L
1100-8xx 280x20-LV/HV	23.6	250	5.9	2-4 2-4s1p	3-5 3-5s1p	3-12 3-9s1-2p	3-18 3-9s1-3p	3-8 3-8s1p	3-7 3-7p1s	3-6 3-6s1p
2000-8xx 280x20-LV/HV	42.7	250	10.7	1-2 1-2s1p	2 2s1p	2-6 2-5s1-2p	2-10 2-5s1-3p	2-4 2-4s1p	2-3 2-3s1p	2-3 2-3s1p
2200-8xx 560x20-HV	27.1	250	11.8	1-2 1-2s1p	2 2s1p	2-6 2-4s1-2p	2-9 2-4s1-3p	2-4 2-4s1p	2-3 2-3s1p	2-3 2-3s1p
4000-8xx 560x20-HV	85.3	250	21.3			1-2 1-2s1-2p	1-4 1-2s1-3p	1-2 1-2s1p		
4FT non-SELV (2 x 2200 lm)	94.3	250	23.6			1-2 1-2s1-2p	1-4 1-2s1-3p	1-2 1-2s1p		
4FT non-SELV (2 x 4000 lm)	170.7	250	42.7			1	1-2 1s1-2p	1		
5FT non-SELV (2 x 2200 lm + 1 x 1100 lm)	117.9	250	29.5		1	1-2 1s1-2p	1-3 1s1-3p	1	1	1
5FT non-SELV (2 x 4000 lm + 1 x 2000 lm)	213.4	250	53.3			1	1-2 1s1p			

\* These combinations are valid if the modules are driven with nominal current. If other currents are used, other combinations are possible.

## 5 Thermal considerations

At nominal operating conditions, with the PrevaLED® Linear G5/G6 mounted onto or into a luminaire housing with heat exchange to the environment, no special additional heat sink is needed to avoid exceeding  $t_c \text{ max} = 75^\circ\text{C}$ .

To avoid overheating, it is nevertheless strongly recommended to check the LED module temperature in any newly designed luminaires.

It should also be mentioned here that lower  $t_c$  point temperatures on the LED module increase the module's efficacy. Therefore, providing efficient cooling for the PrevaLED® Linear G5/G6 LED modules increases the system efficacy of the luminaire/application.

### 5.1 Introduction and definitions

For any LED module, including the PrevaLED® Linear G5/G6 family, different temperatures ( $t_p$ ,  $t_c$ ,  $t_c \text{ max}$  etc.) are mentioned in the datasheet. They are sometimes confusing, therefore a short overview should be given at the beginning of this chapter:

- $t_p$  is the performance temperature of the module. That means that all the tables, diagrams and numbers in the datasheet (and in this technical application guide) refer to the performance temperature  $t_p$  (if not mentioned otherwise).
- $t_c$  is the critical module temperature of the LED module. Up to this temperature, one special feature can be guaranteed (e.g. the efficacy of the LED module at nominal current is higher than 150lm/W up to a temperature of  $t_c = 50^\circ\text{C}$ ).
- $t_c \text{ max}$  is the absolute maximum temperature up to which the operation of the LED module is recommended.

All the temperatures mentioned above are measured at the same point on the LED module, which is (mostly for historical reasons) called the " $t_c$  point" of the LED module. Its position on the PrevaLED® Linear G5/G6 LED modules is shown below.

### 5.2 $t_c$ location and measurement

Proper thermal design of an LED luminaire is critical for achieving best performance and ensuring long lifetime of all components. To achieve a lifetime of 50000 hours (L80B10), the sufficient heat exchange and thermal conduction between the light engine and the luminaire housing has to be verified by measuring the temperature at the  $t_c$  point.

The maximum temperature reached at the  $t_c$  point must not exceed  $75^\circ\text{C}$ . This reference point for PrevaLED® Linear G5/G6 is shown in the image below for the 1100-lm/280-mm LED module type (for the other LED module types, the position is similar).

### Position of the $t_c$ measurement point on PrevaLED® Linear G5/G6 LED modules





The easiest way to measure the temperature at the  $t_c$  point is by using a thermocouple. It is recommended to use a thermocouple that can be glued onto the LED module. Make sure that the thermocouple is fixed with direct contact to the  $t_c$  point.

### Examples of suitable thermocouples



### Different thermocouples

Illustration	Description	Temperature range [°C]
	PVC-insulated thermocouple	-10 ... +105
	PFA-insulated thermocouple	-75 ... +260
	Sprung thermocouple	-75 ... +260

### Thermocouple mounted onto a PrevaLED® Linear G5/G6 module

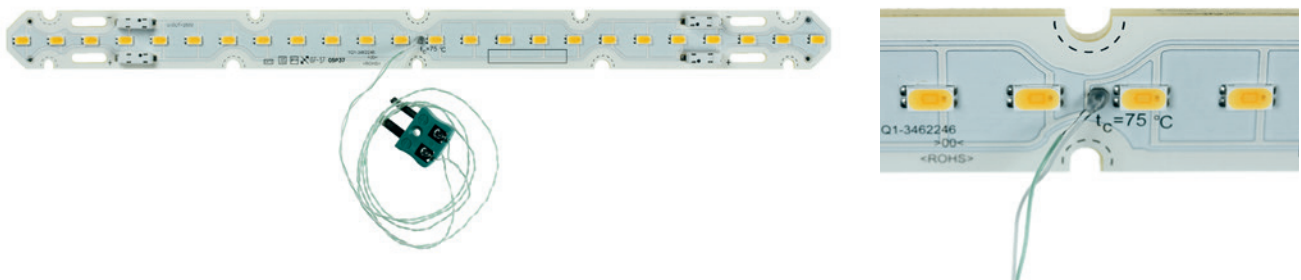

#### 5.3 Forward voltage as a function of $t_c$ point temperature

The diagram on the right shows the relative dependence of the forward voltage on the temperature at the  $t_c$  point of the LED module (down to a temperature of 20 °C). The voltage increases with decreasing temperature. Therefore, when looking for a suitable LED driver, the forward voltage of the cold system at the coldest specified temperature has to be considered.

#### Relative forward voltage as a function of $t_c$ point temperature

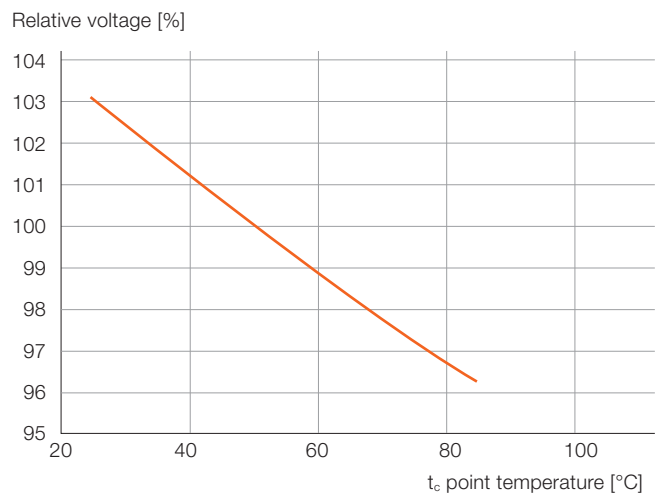

## 6 Lifetime and lumen maintenance

For the definition of the lifetime of an LED module, see IEC/PAS 62717, where the following types are defined:

The luminous flux of an LED module decreases over its lifespan. This decrease is specified by the L value. LXX means that XX% of the initial light output is emitted by the LED module (e.g. L70 = 70 %). The L value is always connected to an operating time and defines the lifetime of an LED module. Please be aware that the L value is a statistical value. Therefore, the decrease in light output can and will vary for different modules.

The B value specifies how many LED modules are below a stated limit, e.g. B50 means that 50 % of the LED modules are below a given L value.

The C value gives the number of fatal failures, meaning the number of LED modules that are destroyed and do not emit any light at all (e.g. C10 after 50000 hours means that after 50000 hours in operation, 10 % of the LED modules do not emit any light).

The F value is the combination of the B and C value, meaning that both fatal failures and degradation are considered.

### Some examples:

- L0C10 is the lifetime where the light output is 0 % for 10 % of the LED modules.
- L70B50 is the lifetime where the light output is  $\geq 70$  % for 50 % of the LED modules. The B value includes only gradual reduction of lumen output over time (not the abrupt flux degradation).
- L70F50 is the lifetime where the light output is  $\geq 70$  % for 50 % of the LED modules. The F value includes reduction of lumen output over time including abrupt degradation (flux = 0).

PrevaLED® Linear G5/G6 LED CRI >80 modules have a lifetime of 50000 hours (L80B10) at a  $t_c$  point temperature of 55 °C. This means that after 50000 hours, a minimum of 90 % of the utilized LED modules will maintain at least 80 % of the initial luminous flux.

PrevaLED® Linear G5/G6 LED CRI >90 modules have a lifetime of 50000 hours (L80B50) at a  $t_c$  point temperature of 55 °C. This means that after 50000 hours, a minimum of 50 % of the utilized LED modules will maintain at least 80 % of the initial luminous flux.

### Please note:

A higher  $t_c$  temperature leads to a shorter lifetime of the LED module. Moreover, the failure rate will also increase.

Average lifetime vs.  $t_c$  at CRI >80

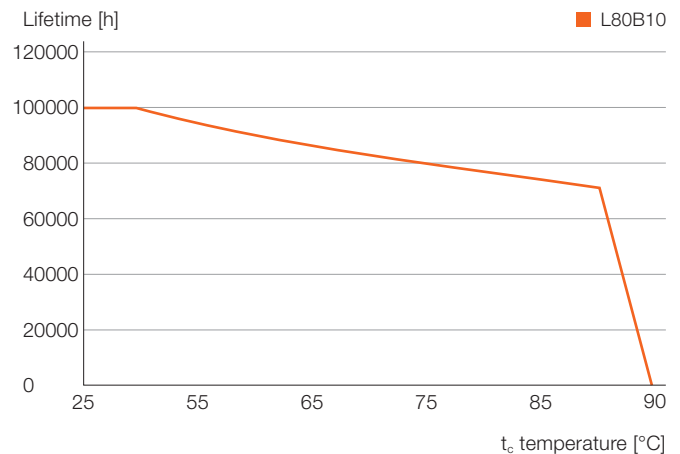

Average lifetime vs.  $t_c$  at CRI >90

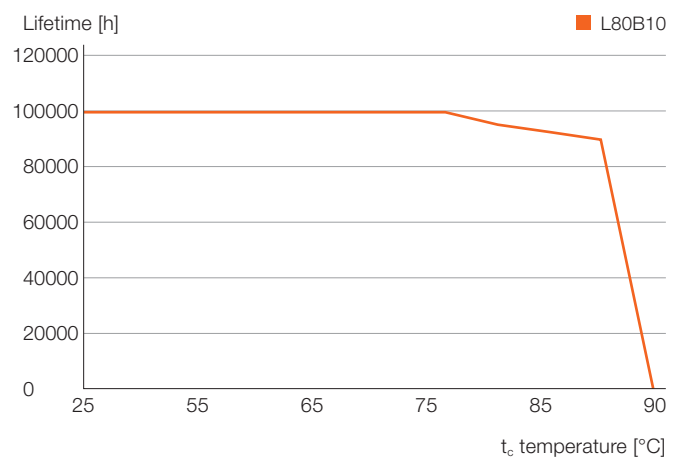

**Illustration of the temperature-dependent lumen maintenance (B10) at current  $I_{nom}$  and CRI > 80**

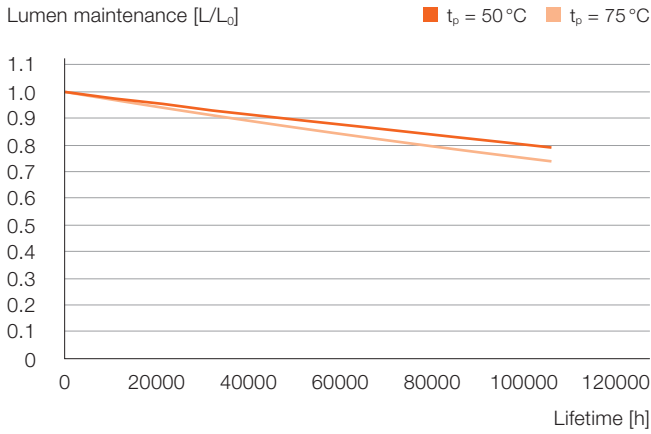

**Illustration of the temperature-dependent lumen maintenance (B50) at current  $I_{nom}$  and CRI > 90**

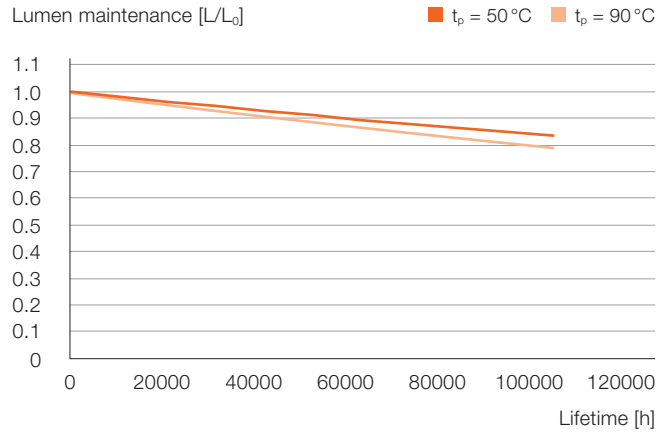

**Lifetime data at CRI > 80, CRI > 90**

		LxBy					
		70		80		90	
		10	50	10	50	10	50
[mA]		Lifetime [h]					
$t_p\text{ [°C]} = 40$	$I_{rated}$	> 70000	> 70000	> 70000	> 70000	36000	40000
$t_p\text{ [°C]} = 45$	$I_{rated}$	> 70000	> 70000	> 70000	> 70000	35000	39000
$t_p\text{ [°C]} = 50$	$I_{rated}$	> 70000	> 70000	69000	> 70000	33000	37000
$t_p\text{ [°C]} = 55$	$I_{rated}$	> 70000	> 70000	66000	> 70000	32000	36000
$t_p\text{ [°C]} = 60$	$I_{rated}$	> 70000	> 70000	64000	> 70000	31000	35000
$t_p\text{ [°C]} = 65$	$I_{rated}$	> 70000	> 70000	62000	69000	30000	33000
$t_p\text{ [°C]} = 70$	$I_{rated}$	> 70000	> 70000	60000	67000	29000	32000
$t_p\text{ [°C]} = 75$	$I_{rated}$	> 70000	> 70000	58000	65000	28000	31000

## 7 Mechanical considerations

### 7.1 LED module dimensions

The PrevaLED® Linear G5/G6 family has seven types of LED module dimensions:

- 62 mm x 20 mm x 5 mm
- 70 mm x 20 mm x 5 mm
- 140 mm x 20 mm x 5 mm
- 280 mm x 20 mm x 5 mm
- 560 mm x 20 mm x 5 mm
- 1120 mm x 20 mm x 5 mm
- 1400 mm x 20 mm x 5 mm

The different module lengths are available with the following nominal luminous fluxes:

- 62 mm: 245 lm
- 70 mm: 275 lm
- 140 mm: 550 lm
- 280 mm: 1100, 2000 lm
- 560 mm: 2200, 4000 lm
- 1120 mm: 4400 lm
- 1400 mm: 5500 lm

#### PrevaLED® Linear G5/G6: PL-LIN-Z6 245-xxx 62X20-HV

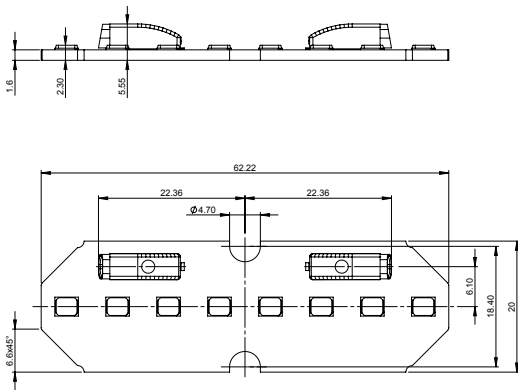

#### PrevaLED® Linear G5/G6: PL-LIN-Z6 275-xxx 70X20-LV

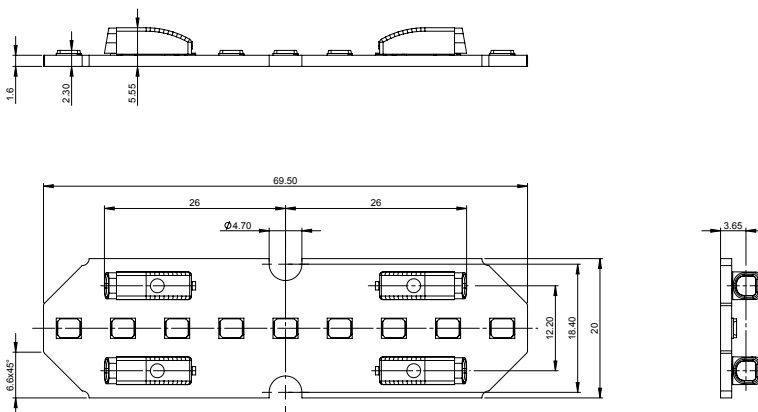



**PrevaLED® Linear G5/G6: PL-LIN-Z5 4400-xxx 1120X20-HV**

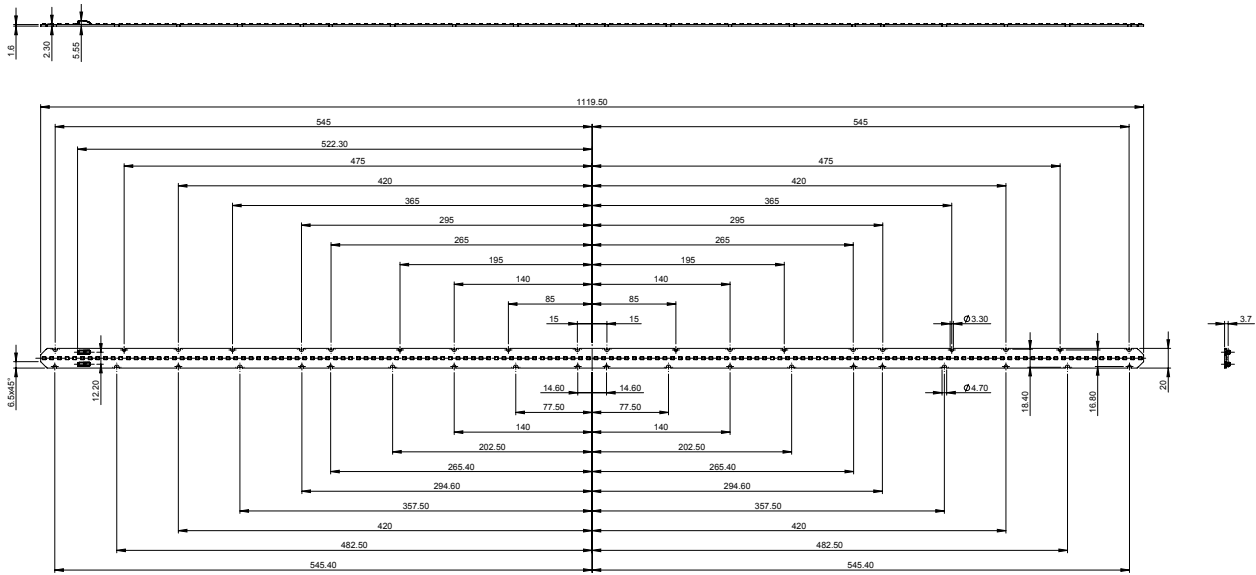

**PrevaLED® Linear G5/G6: PL-LIN-Z5 5500-xxx 1400X20-HV**

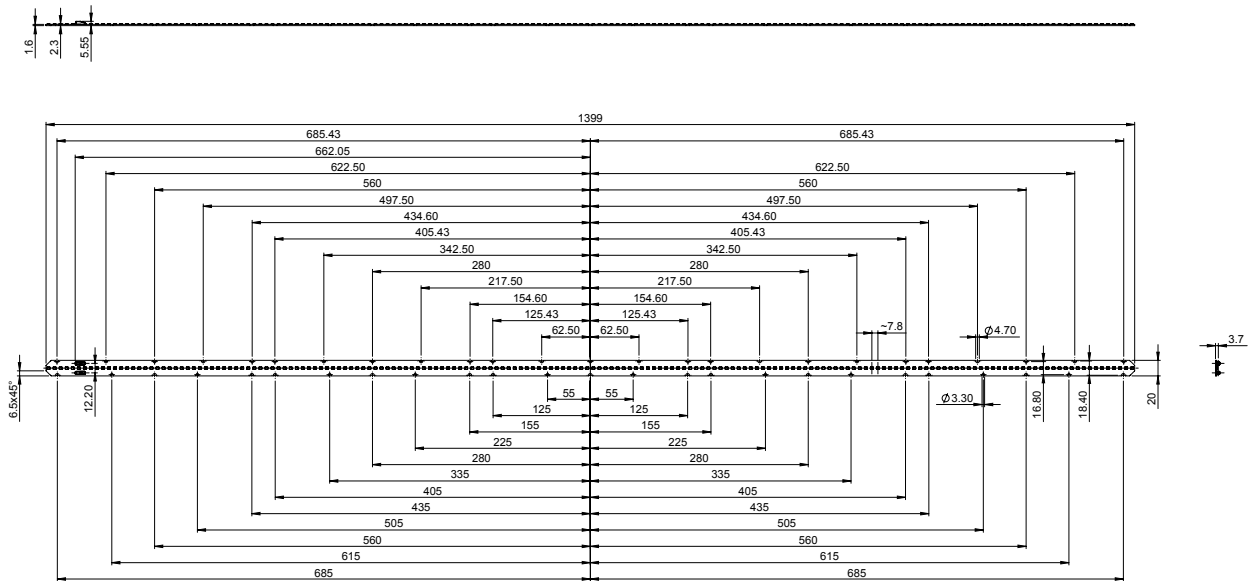

**PrevaLED® Linear G5/G6: PL-LIN-Z5/Z6 2200-xxx 560X20-LV**

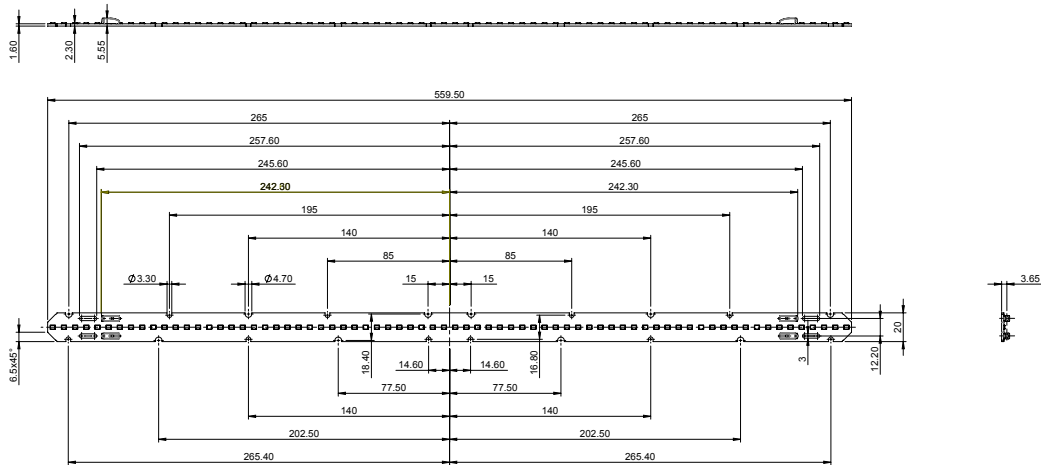

**PrevaLED® Linear G5/G6: PL-LIN-Z6 550-xxx 140X20-LV**

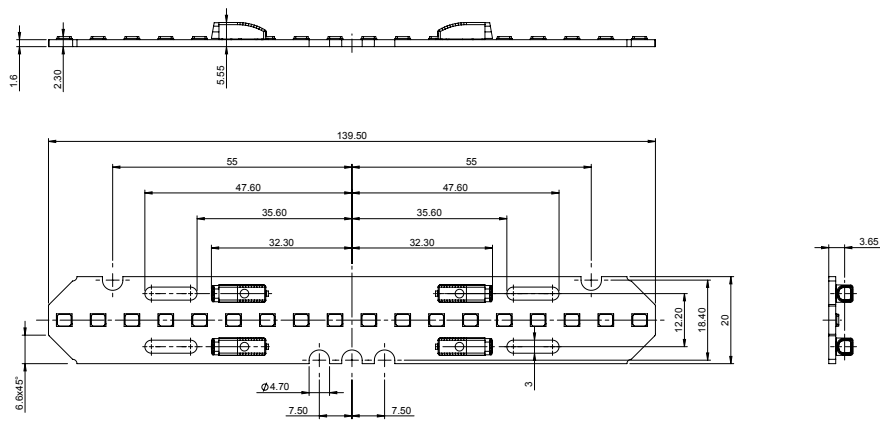

**PrevaLED® Linear G5/G6: PL-LIN-Z5/Z6 1100-xxx 280X20-LV/HV**

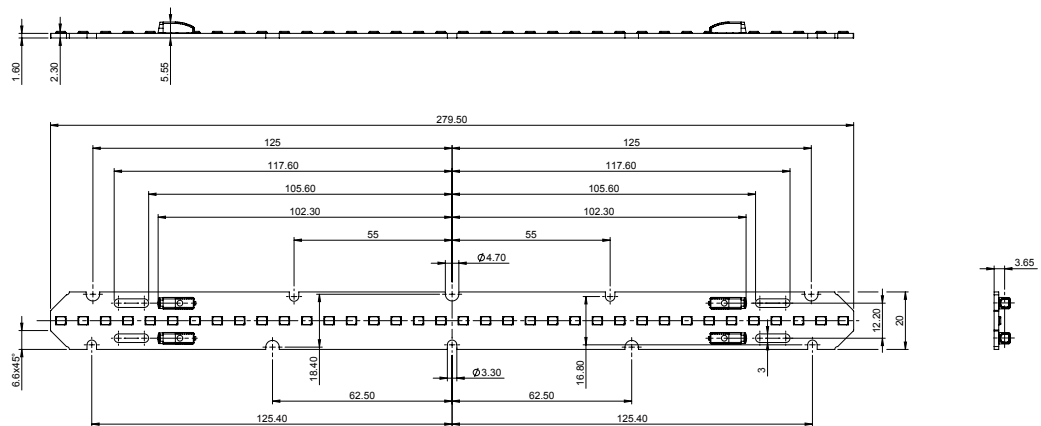

**PrevaLED® Linear G5/G6: PL-LIN-Z5/Z6 4000-xxx 560X20-LV**

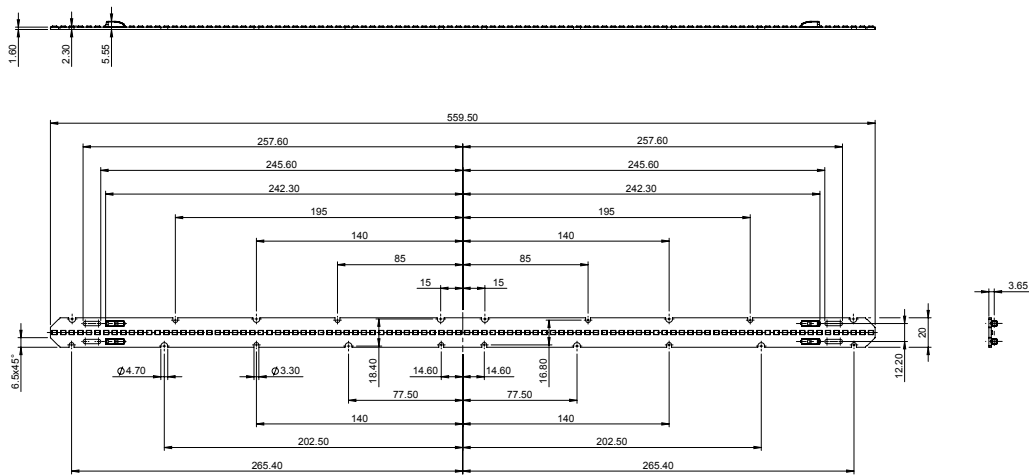

**Module dimensions overview**

	L [mm]	W [mm]	H1 (PCB thickness) [mm]	H2 (LED module height) [mm]
PL-LIN-Z6 245-xxx 62X20-HV	62.22	20	1.60	5.55
PL-LIN-Z6 275-xxx 70X20-LV	69.50	20	1.60	5.55
PL-LIN-Z5/Z6 2000-xxx 280X20-LV-HV	279.50	20	1.60	5.55
PL-LIN-Z5/Z6 2200-xxx 560X20-HV	559.50	20	1.60	5.55
PL-LIN-Z5/Z6 4000-xxx 560X20-HV	559.50	20	1.60	5.55
PL-LIN-Z5 4400-xxx 1120X20-HV	1119.50	20	1.60	5.55
PL-LIN-Z5 5500-xxx 1400X20-HV	1399	20	1.60	5.55
PL-LIN-Z5/Z6 2200-xxx 560X20-LV	559.50	20	1.60	5.55
PL-LIN-Z6 550-xxx 140X20-LV	139.50	20	1.60	5.55
PL-LIN-Z5/Z6 1100-xxx 280X20-LV/HV	279.50	20	1.60	5.55
PL-LIN-Z5/Z6 4000-xxx 560X20-LV	559.50	20	1.60	5.55

## 7.2 Number of LEDs, LED pitch

### Number of LEDs and LED pitch for the different modules in the PrevaLED® Linear G5/G6 family

Product name	Number of LEDs	Pitch [mm]
PL-LIN-Z5 1100-8xx 280X20-LV/HV	36	7.78
PL-LIN-Z5 2000-8xx 280X20-LV/HV	48	5.83
PL-LIN-Z5 2200-8xx 560X20-LV/HV	72	7.78
PL-LIN-Z5 4000-8xx 560X20-LV/HV	96	5.83
PL-LIN-Z5 4400-8xx 1120X20-HV	144	7.78
PL-LIN-Z5 5500-8xx 1400X20-HV	180	7.78
PL-LIN-Z6 245-9xx 62X20-HV	8	7.78
PL-LIN-Z6 275-9xx 70X20-LV	9	7.78
PL-LIN-Z6 1100-9xx 280X20-LV/HV	36	7.78
PL-LIN-Z6 2000-9xx 280X20-LV/HV	48	5.83
PL-LIN-Z6 2200-9xx 560X20-LV/HV	72	7.78
PL-LIN-Z6 4000-9xx 560X20-LV/HV	96	5.83
PL-LIN-Z6 245-8xx 62X20-HV	8	7.78
PL-LIN-Z6 275-8xx 70X20-LV	9	7.78
PL-LIN-Z6 550-8xx 140X20-LV	18	7.78
PL-LIN-Z6 1100-8xx 280X20-LV/HV	36	7.78
PL-LIN-Z6 2000-8xx 280X20-LV/HV	48	5.83
PL-LIN-Z6 2200-8xx 560X20-LV/HV	72	7.78
PL-LIN-Z6 4000-8xx 560X20-LV/HV	96	5.83

### 7.3 Mechanical protection

For operation in damp, wet or dusty environments, the user has to make sure that an adequate ingress protection (IP) is chosen. The LED module has to be protected by a suitable IP rating of the luminaire housing. Please consider the luminaire standard IEC 60598 as well as the different requirements.



### 7.4 Mounting instructions

Please apply force only to the dedicated mounting positions. Strong mechanical stress can lead to irreversible damage of the LED module. To fix the module to the fixture, you can use M4 screws according to DIN 7984 or DIN EN ISO.

The maximum allowed screw head diameter (without using an isolating washer between the screw and the mounting hole) is 7.5 mm. With larger screw heads, the minimum distance between the screw and other conductive parts on the PrevaLED® Linear LED module can be below the limit for creepage distances.

The maximum torque that should be applied on the screws depends on factors such as the screw type and the luminaire material. It is also influenced by the usage of washers. In most cases, a torque between 0.5 Nm and 1 Nm is enough to fix the LED module in the luminaire housing and will not damage the module.

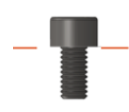
### Possible screws

Cylinder head, torx drive	M4 screw (ISO 4762)	
Diameter	4.0 mm	
Head diameter	7.0 mm	
Head height	4.0 mm	
Flat head, button head Torx drive, hex drive	M4 screw (ISO 7380)	
Diameter	4.0 mm	
Head diameter	7.5 mm	
Head height	2.1 mm	

It is also possible to use clips instead of screws, e.g. the push-to-fix (P2F) connectors from BJB: [www.bjb.com](http://www.bjb.com)

To achieve optimal fixation of the LED module and also optimal thermal management, it is recommended to use all mounting holes in the PrevaLED® Linear G5/G6 LED modules. Nevertheless, it is possible to reduce the number of screws, but in that case thermal behavior and mechanical strength has to be verified.

### Please note:

In any case, it is strongly recommended to perform mechanical and thermal testing of the LED modules in the luminaire.

Please use the dedicated mounting positions only for the fixation of the modules.

**Warning:**

Do not use the cut-outs for the wiring to mount an LED module!

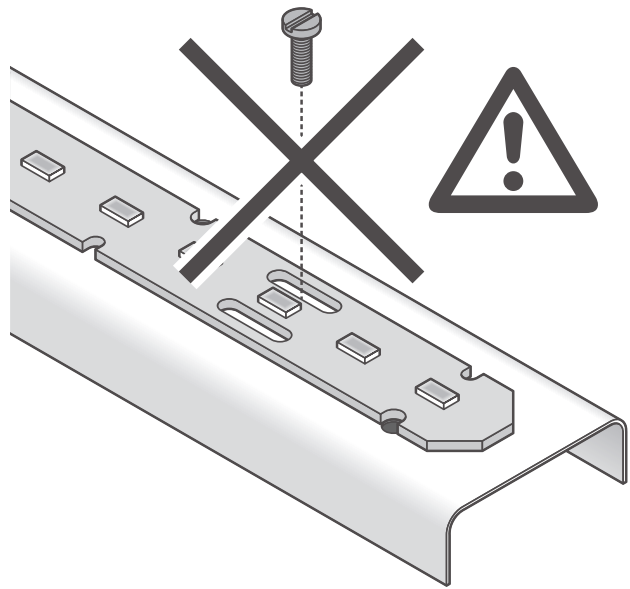
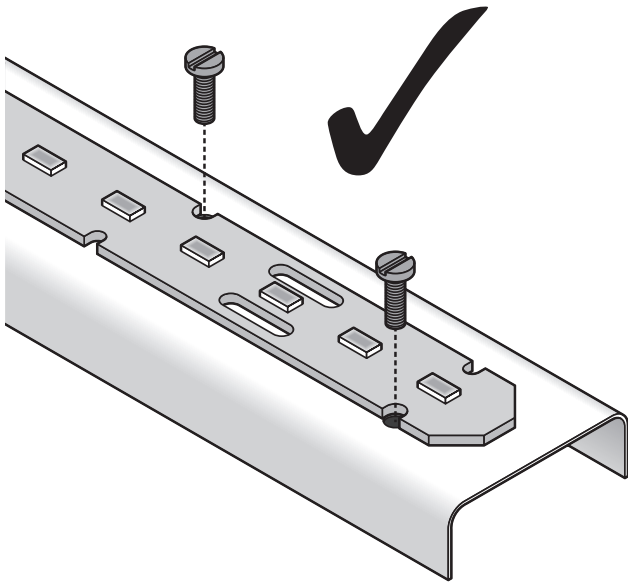

## 8 Safety information

The LED module itself and all its components must not be mechanically stressed.

### **The modules are intended for operation only with matching OPTOTRONIC® LED drivers**

To also ease the luminaire/installation approval, electronic control gears for LEDs or LED modules should carry the CE mark and be ENEC-certified. In Europe, the declarations of conformity must include the following standards: CE: EC 61347-2-13, EN 55015, IEC 61547 and IEC 61000-3-2 – EN-EC: 61347-2-13 and IEC/EN 62384.

Also check for the mark of an independent authorized certification institute.

Please see the relevant brochure for more detailed information (see “Related and Further Information”).

- Installation of LED modules (with power supplies) needs to be made with regard to all applicable electrical and safety standards. Only qualified personnel should be allowed to perform installations.
- Pay attention to standard ESD precautions when installing the module.
- Photobiological safety according to IEC 62471, risk group RG1
- Max. voltage  $U\text{-OUT} = 250\text{V}$  for operation on non-isolated and SELV LED control gears.

### **Disclaimer**

All information contained in this document has been collected, analyzed and verified with great care by Inventronics. However, Inventronics is not responsible for the correctness and completeness of the information contained in this document and Inventronics cannot be made liable for any damage that occurs in connection with the use of and/or reliance on the content of this document. The information contained in this document reflects the current state of knowledge on the date of issue.

Use our contact form

[www.inventronicsglobal.com/contact-us](http://www.inventronicsglobal.com/contact-us)



Service contact:  
**Inventronics GmbH**  
Parkring 31-33, 85748 Garching, Germany  
[www.inventronicsglobal.com](http://www.inventronicsglobal.com)  
[support@inventronicsglobal.com](mailto:support@inventronicsglobal.com)

**inventronics**