

Mounting Adapter

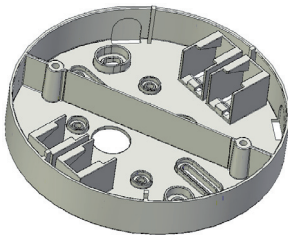

Description

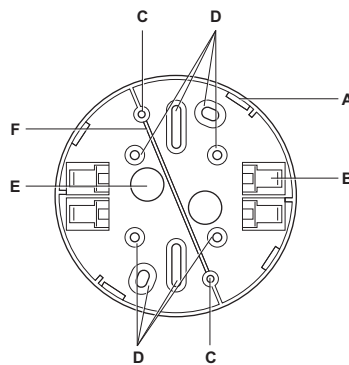

Purpose and application

The mounting adapter ensures that OSRAM motion detectors specifically designed for this device can be simply and securely mounted in compliance with the CE guidelines.

Design

The mounting adapter is made up of the following components:

- Removable cable guide through adapter wall (A)
- Holders for cable clamps (B)
- Screw holes for attaching the motion detector (C)
- Screw holes for wall mounting (D)
- Cable guide through adapter base (E)
- Removable partition wall (F)

Mounting adapter for motion detector Fitting instructions

Installation

Safety instructions

The mounting adapter must only be installed and put into operation by a qualified electrician. The applicable safety regulations and accident prevention regulations must be observed.



WARNING!

Exposed, live cables or damaged housing.

Danger of electric shock!

- Only work on the motion detector when it is de-energised.

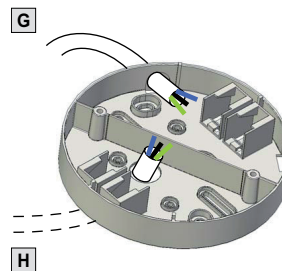

Procedure

- ① Select the installation location. Follow the fitting instructions of the motion detector.
- ② Insert the cable clamps in the holders (B).
- ③ Pass the connection cable through the cable guide:
 - Surface-mounting (G): use cable guide through adapter wall
 - Flush-mounting (H): use cable guide through adapter base
- ④ Attach the mounting adapter to the wall or ceiling via the screw holes (D).
- ⑤ Attach the connection cable to the cable clamps.
- ⑥ Attach the motion detector via the screw holes (C) on the mounting adapter. Follow the fitting instructions of the motion detector.

